

**Thank you for choosing a NIVELCO instrument.**  
**We are sure that you will be satisfied throughout its use!**

## 1. GENERAL INTRODUCTION, OPERATION

NIVOFLIP MAK-100-□ type magnetic level switches are suitable for level switching of various liquids. MAK-100 type magnetic level switches are used for magnetic-lamella bypass level indicator (named NIVOFLIP) as an optional level switch.

### OPERATION PRINCIPLE:

Mounted on suitable connection flanges on the side of the tank the liquid level in the bypass tube and the tank is equal. In the stainless steel bypass tube a magnetic float tracks the level of the liquid. In the float a permanent magnet is incorporated, which operates the MAK-100 type adjustable positioned magnetic level switch through the stainless steel side of the tube, and provides non-contact signal transfer to the microswitch.

Electronic connection is performed with cable gland, wired with a maximal 2.5 mm<sup>2</sup> cross sectioned cable. Installation of the level switch is made by 2 pieces of hose clamps. Position of the switch can be changed to adjust the needed switching level. The level switches are available in normal and Ex versions.

## 2. TECHNICAL DATA

Type	MAK-100-0	MAK-100-6	MAK-100-7
Medium temperature	max. +130 °C	See: Temperature classes table	
Ambient temperature	-20 °C ... +80 °C		
Material of the switch-housing	Paint coated aluminium cast		
Switch	1 microswitch, with NO / NC contacts		
Switch rating	250 V AC12 2.5 A 220 V DC13 0.3 A	Only Ex ia certified and approved contact isolator should be used for supply!	250 V AC12 2.5 A 220 V DC13 0.3 A
Electrical connections	cable gland: M20x1.5 terminal for max. 2.5 mm <sup>2</sup> wire cross section		
Mechanical protection	IP65		
Electrical protection	Class I		
Ex marking	–	II 1G	II 2G Ex db eb mb IIC T6...T4
Mass	1.5 kg		

\* The Ex d and Ex m protection mode apply to the built-in microswitch!

### 2.1 GENERAL DATA

Class	Temperature classes		
	T6	T5	T4
Max. medium temperature	+80 °C	+95 °C	+130 °C
Ambient temperature	-20 °C ... +60 °C	-20 °C ... +70 °C	-20 °C ... +80 °C

### 2.2 ACCESSORIES

- User's manual
- Warranty card
- Declaration of Conformity
- 2 pcs. Hose clamps

### 2.3 ORDER CODE

NIVOFLIP MAK-100-□

Type	Code
Normal	0
Ex II 1G (ATEX)	6
II 2G Ex db eb mb IIC T6...T4 (ATEX)	7

### 2.5 MOUNTING

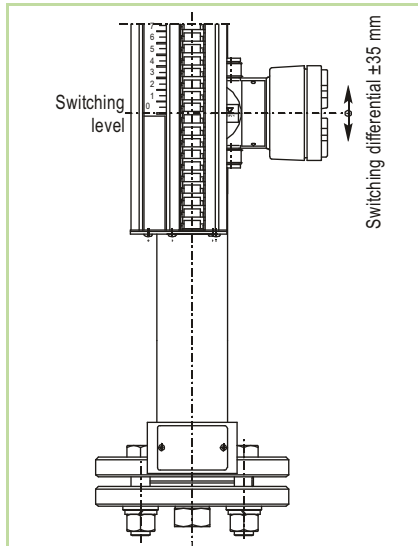

### 2.6 MOUNTING RECOMMENDATION

#### Default start-up:

Before start-up move the float to the top end, and all the way back to the bottom point.

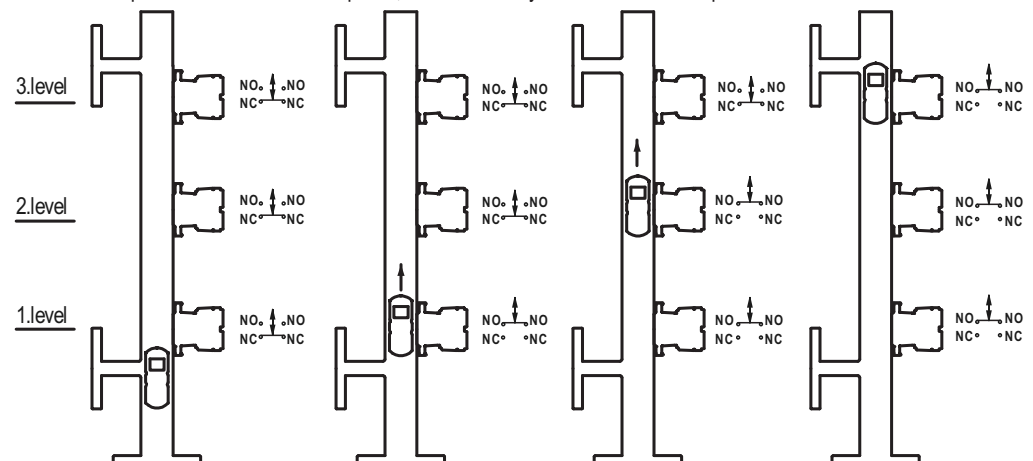

**NIVOFLIP**  
MAGNETIC LEVEL SWITCH

USER'S MANUAL  
FOR MAK-100-□



Dodávateľ:  
**MICROWELL spol. s r. o.**  
 SNP 2018/42, 927 00 Šafa  
 Tel.: (+421) 31/ 770 7585, 770 7587  
 E-mail: microwell@microwell.sk  
 http://www.microwell.sk



Manufacturer:  
**NIVELCO Process Control Co.**  
 H-1043 Budapest, Dugonics u. 11.  
 Tel.: (36-1) 889-0100 ■ Fax: (36-1) 889-0200  
 E-mail: sales@nivelco.com ■ www.nivelco.com



**NIVELCO**

### 2.4 DIMENSIONS

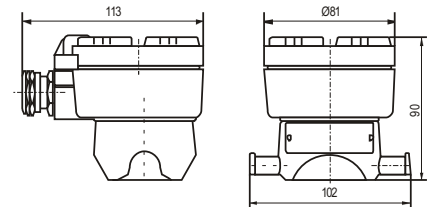

### 3. WIRING

#### 1. level – Low fail safe-

Low fail safe mode: if the level is lower than the switch point the micro-switch interrupts the signal.  
Two-wire signal cable wiring to NO-NO contacts.

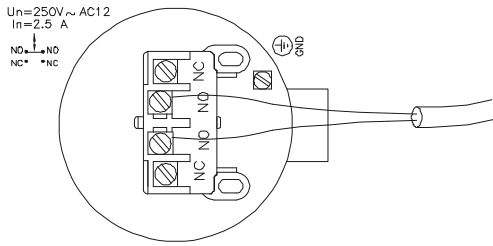

#### 3. level – High fail safe-

High fail safe mode: if the level is higher than the switch point the micro-switch interrupts the signal.  
Two-wire signal cable wiring to NC-NC contacts.

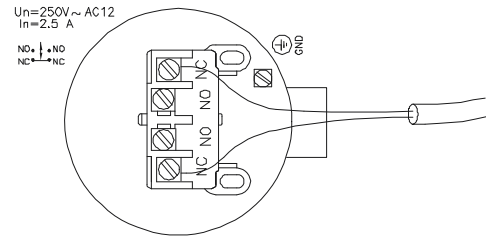

#### 2. level – user level indicator- Wiring on demand with NO-NO or NC terminals

##### Filling control example:

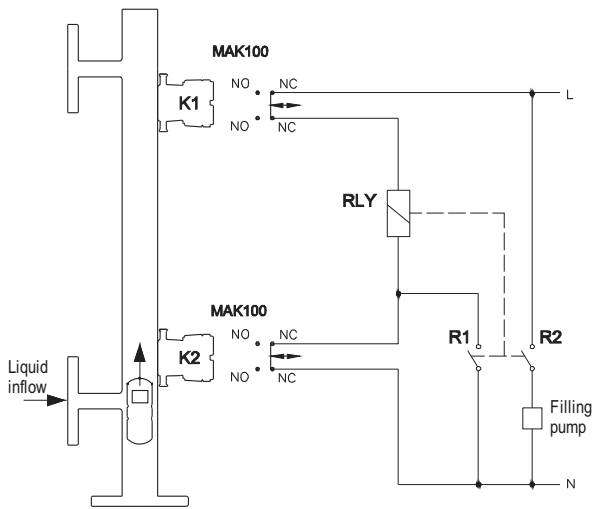

##### Emptying control example:

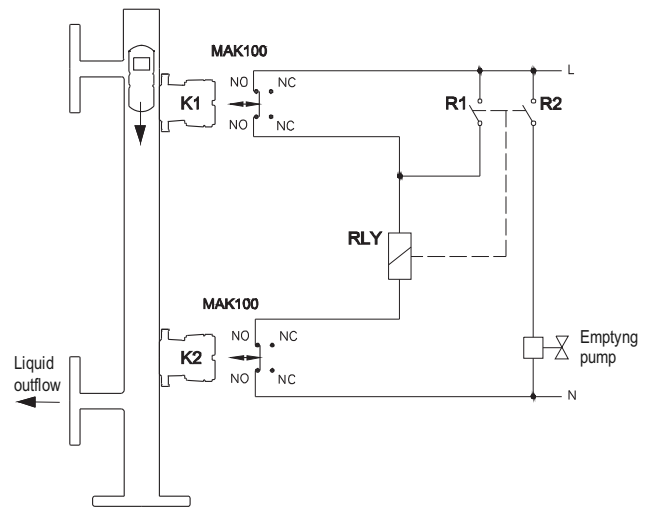

The self-holding relay circuit and the cabling are not part of the unit!

### 4. SPECIAL CONDITIONS OF SAFE USE

- 4.1. MAK-100-6Ex:  
The limit switch must be connected to a voltage source of a certified type for use in explosive atmosphere from  $\text{Ex II (1) G [Ex ia] IIB}$  resp.  $\text{Ex II (1) G [Ex ia] IIC}$  and its output circuit approved as intrinsically safe.
- 4.2. MAK-100-6Ex:  
The housing of equipment is made of aluminium alloy. If the equipment is installed in a location where the device must have Ga protection level, it must be installed in order to avoid ignition sources of rare occurrence of shock and friction sparks.
- 4.3. MAK-100-7Ex:  
The equipment must be protected against overload with a fuse 2.5 A marked "T".
- 4.4. The housing of equipment must be connected to the EP network.
- 4.5. The temperature class depends on the ambient temperature resp. medium temperature (See: Temperature classes table).

### 5. MAINTENANCE

The instrument do not require maintenance, but the instrument (depending on the application) may need to be checked or cleaned regularly.

### 6. STORAGE CONDITIONS

Ambient temperature: -25 °C ... max: +80 °C (see: "Temperature classes table")  
Relative humidity: max. 98% non-condensing!

mak1100a0600h\_04  
November 2018

NIVELCO reserves the right to change technical specifications without notice.