

Thank you for choosing NIVELCO instrument
We are sure that you will be satisfied throughout its use!

NIPRESS

DRF-7□□-□
 PRESSURE TRANSMITTER

User's manual



Dodávateľ:
MICROWELL spol. s r. o.
 SNP 2018/42, 927 00 Šala
 Tel.: (+421) 31/ 770 7585, 770 7587
 E-mail: microwell@microwell.sk
 http://www.microwell.sk



Manufacturer
NIVELCO Process Control Co.
 H-1043 Budapest, Dugonics u. 11.
 Phone: (36-1) 889-0100 Fax: (36-1) 889-0200
 E-mail: sales@nivelco.com www.nivelco.com

NIVELCO

1. APPLICATION

NIPRESS D-700 series pressure transmitters measure pressure and convert it into voltage and current output. They can be used in 2- and 3-wire systems. With a wide range of technical features, the transmitter family is capable of measuring relative pressures in a variety of accuracy classes. The NIPRESS D-700 devices can only be used for static pressure. Their design, overload capability, applicability over a wide temperature range and the ability to install in any position allow transmitters to be used in a wide variety of industrial conditions.

2. TECHNICAL SPECIFICATION

TYPE		DRF-7□□-□
Measurement range		0 – 20 bar according to the order code
Overload capability		According to the order code
Accuracy		±0.5%; P _n ≥ 0.6 bar: ±0.25%; ±1% (with teflon coating)
Medium temperature ⁽¹⁾		-40 °C ... +125 °C (-40 °F ... +257 °F)
Ambient temperature ⁽¹⁾		-40 °C ... +85 °C (-40 °F ... +185 °F) (with integral cable: -5 °C ... +70 °C [+23 °F ... +158 °F])
Sensor type		Capacitive
Materials of the wetted parts	Sensor ⁽²⁾	Aluminium oxide ceramic (flush membrane)
	Sensor sealing	FKM, EPDM: -40 °C ... +125 °C (-40 °F ... +257 °F) FFKM: -15 °C ... +125 °C (+5 °F ... +257 °F)
	Process connection	Stainless steel 1.4404 (316L); optional: PVDF
Housing		Stainless steel 1.4404 (316L); optional: PVDF
Output		2-wire: 4 – 20 mA; 3-wire: 0 – 10 V
Power supply		2-wire, 4 – 20 mA output: U _{Supply} = 9 – 32 V DC; 3-wire, 0 – 10 V DC output: U _{Supply} = 12.5 – 32 V DC
Load resistance		2-wire, 4 – 20 mA current output: R _{max} = [(U _{Supply} - 9 V) / 0.02 A] Ω 3-wire, 0 – 10 V DC voltage output: R _{min} > 10 kΩ
Process connection ⁽¹⁾		1½" BSP
Electrical connection		ISO 4400 / M12x1 (4 pin) / integral cable
Ingress protection		IP65 (ISO 4400) / IP67 (M12x1) / IP68 (integral cable with capillary tube)
Electric protection		Class III (SELV)
Mass		~ 0.2 kg

⁽¹⁾ Minimum temperature with PVDF process connection is -30 °C (-22 °F)

⁽²⁾ Optional: Teflon coating (with 1% accuracy)

SPECIALDATA FOR Ex CERTIFIED MODELS (ONLY FOR 4 – 20 mA / 2-WIRE)

TYPE	DRF-7□□-6Ex
Ex marking	(Pending)
Power supply	U _{Supply} = 14 V – 28 V DC
Intrinsically safe data	Use only with Ex ia certified power supply! U _{max} = 28 V DC, I _{max} = 93 mA, P _{max} = 660 mW, C _i = 27 nF, L _i ≈ 5 μH
Permissible temperatures for environment	Zone 0: -20 °C ... +60 °C, 0.8 bar ≤ p _{atm} ≤ 1.1 bar Zone 1, 2: -25 °C ... +70 °C
Connecting cable (in case of a device equipped with integral cable)	Cable capacitance: 100 pF/m, Cable inductivity: 1 μH/m

2.1 ACCESSORIES

- User's manual
- Warranty card
- EU Declaration of Conformity

2.2 ORDER CODE (NOT ALL COMBINATIONS POSSIBLE!)

NIPRESS D R F - 7 □ □ - □

MEASURING METHOD	CODE
Gauge	R

PROCESS CONNECTION	CODE
1½" BSP ⁽³⁾	F

RANGE / OVERLOAD CAPABILITY [bar]	CODE
0 – 0.04 (2)	O
0 – 0.06 (2)	P
0 – 0.1 (4)	1
0 – 0.16 (4)	R
0 – 0.25 (6)	2
0 – 0.4 (6)	3
0 – 0.6 (8)	4
0 – 1 (8)	5
0 – 1.6 (15)	6
0 – 2.5 (25)	7
0 – 4 (25)	8
0 – 6 (35)	9
0 – 10 (35)	A
0 – 16 (45)	B
0 – 20 (45)	T

ACCURACY	CODE
0.25% ⁽¹⁾	1
0.5%	2
1% ⁽²⁾	3

OUTPUT / EX	CODE
4 – 20 mA, 2-wire	2
0 – 10 V, 3-wire	3
4 – 20 mA, 2-wire, / Ex ia	6

⁽¹⁾ p ≥ 0.6 bar

⁽²⁾ With Teflon coating

⁽³⁾ Stainless steel or PVDF

2.3 DIMENSIONS

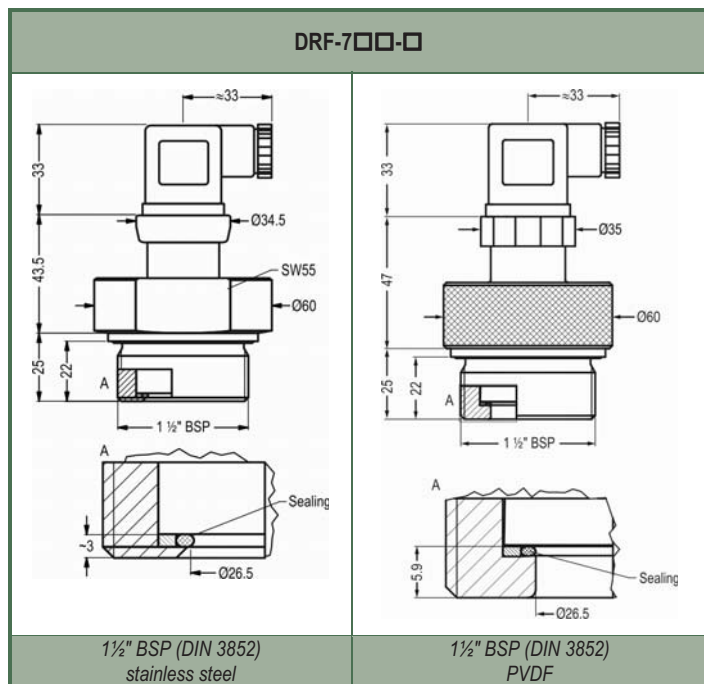

3. SPECIAL CONDITIONS OF SAFE USE

Before turning on the device, make sure the installation is complete, and there are no visible defects. The device may only be used within the limitations specified in the technical specifications.

Protection against electrostatic charge:

The devices may partially contain static charging capable plastic components. The presence of electrostatic charges may cause a risk of spark generation and ignition and therefore electrostatic charges must be completely prevented:

- Use a shielded cable!
- Avoid friction on plastic surfaces!
- Do not clean the device dry! For example, use a wet duster!

Ex ia certified transmitters may only be operated in qualified, certified and approved galvanically isolated intrinsically safe Ex ia circuits complying with the technical data and the device's explosion protection marking. The metal housing of the device must be connected to the EP (equipotential) network!

4. INSTALLATION

Due to its small size and weight NIPRESS D-700 can be directly installed on tanks, pipes, machines, etc. without mounting fittings.

In case of level measurement, the unit should be thread in a stub at the bottom of the tank or the tank wall possibly near to the bottom.

To provide a chance for replacement of the instrument during operation the use of closing armature is recommended. A simple ball valve will be suitable for lower pressure, but for higher pressure (above 6 bar) a three-way blow-off needle-valve is suggested. For medium with temperature over 75 °C (167 °F), application of condensing device would protect the instrument against overheating and extends its lifetime.

The temperature of the condensation in the condensing devices (in the water lodge) is only 10 °C ... 20 °C (18 °F ... 36 °F) higher than the ambient temperature.

Using a longer impulse tube, its proper sloping for the necessary de-aerating and emptying has to be ensured.

Measuring low pressure values in systems with substantial height difference between the transmitter and place of measurement the hydrostatic pressure of the medium in the impulse pipe should be taken into consideration.

In the case of outside installation, the unit is supposed to be protected against rain or splash water, because malfunction may occur if the connector's screw is not tightened properly (i.e. not appropriate sealing).

Installation position: any.

4.1 INSTALLATION INSTRUCTION

Depending on the measured medium, it may cause a hazard to the installer, therefore the wear of suitable protective clothing, gloves, and goggles are recommended.

Torque transmission is only allowed to be applied on the hexagonal screw on the instrument body (torque wrench).

Be careful because the membrane is very vulnerable!

The cylindrical housing of the transmitter must not be gripped and tightened with a pipe wrench!

The plug-in electric connector (ISO 4400) can be unplugged after releasing and removing its fastening screw. The connection insert can be pushed out by a screw driver from the direction of the screw.

Pushing the electric cable through the cable gland it can be connected to the relevant points of the connector. Make sure that the cable gland and the sealing plate of the connector are tightened properly!

Tighten the screw of the connector so that the sealing plate underneath seals properly!

Install the device only in a pressure and current free state!

Choose an installation position to allow the splashed liquid to drain off from the device!

Avoid the mechanical tensioning of the device during installation, especially if the pressure connector is made of PVDF!

For the sake of noise suppression, the transmitter housing is grounded. If the grounding of the process is correct no further grounding is needed, otherwise the instrument should be grounded.

Installation steps:

The specified tightening torques must not be exceeded!

Tightening torques in case of stainless steel process connection:

1 1/2" BSP: max. 25 Nm.

Mounting steps for BSP thread connections according to DIN 3852

Do not use any additional sealing material such as Teflon tape!

Check if the O-ring is undamaged, it has a flawless and clean surface and seated in the designated groove.

Screw the device into the corresponding thread by hand, and tighten the parts with a suitable torque wrench. If your device can be secured with a knurled ring, the pressure transmitter should only be tightened by hand!

5. WIRING

Shielded and twisted multicore cable is recommended for the electrical connection.

For devices with cable gland, make sure that the external diameter of the used cable is within the allowed clamping range! Once connected the wires, tighten the gland screw firmly until proper sealing!

For the installation of a device with an integral cable, the bending radiuses have to comply with the following:

Cable without ventilation tube:

- static installation: 5-fold cable diameter
- dynamic application: 10-fold cable diameter

Cable with ventilation tube:

- static installation: 10-fold cable diameter
- dynamic application: 20-fold cable diameter.

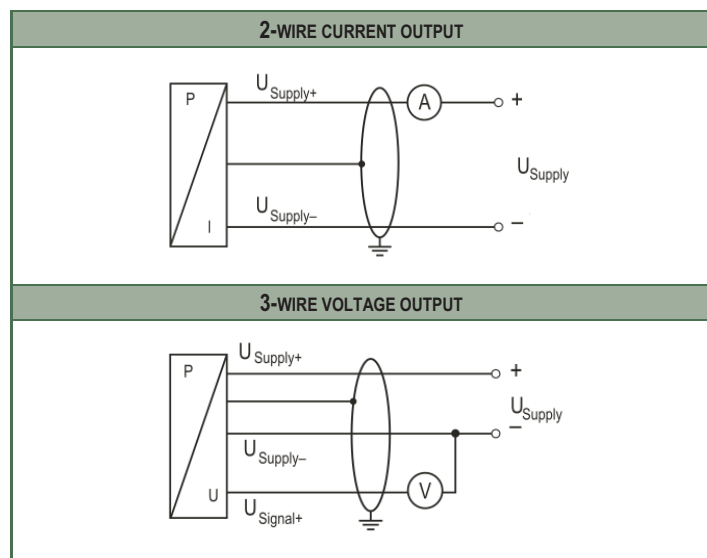

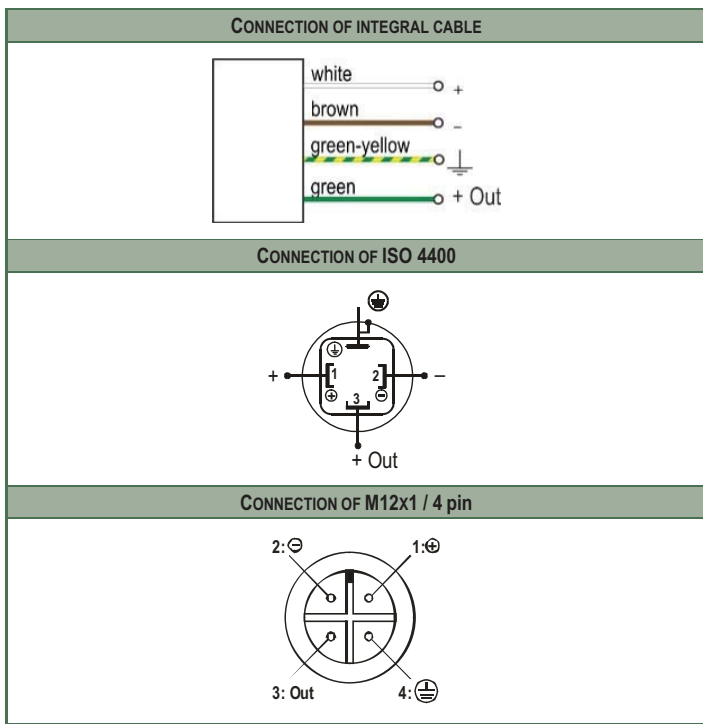

5.1 EXAMPLES OF ARRANGEMENTS

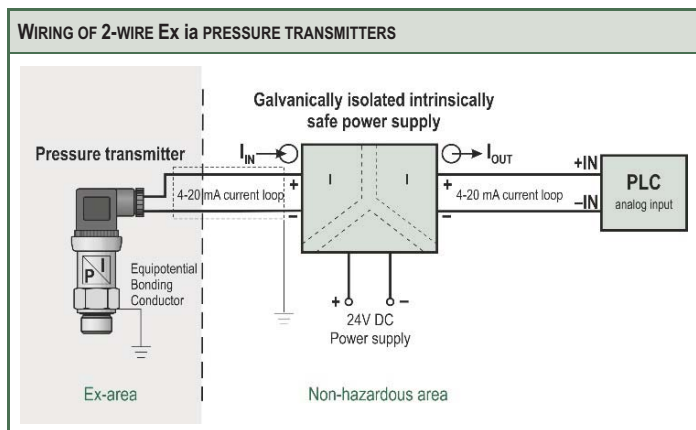
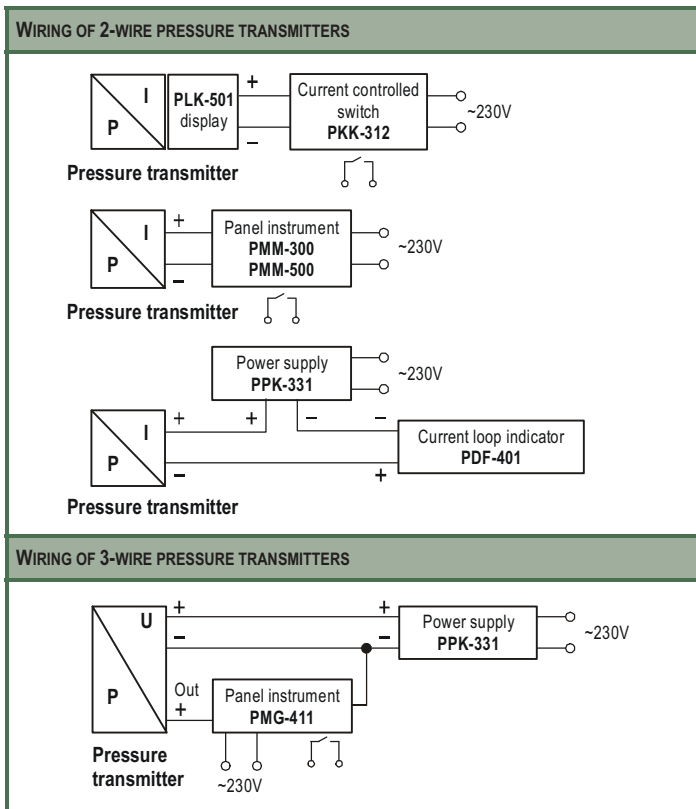

6. TROUBLESHOOTING

Fault	Possible causes	Fault detection / remedy
No output signal:	Connected incorrectly.	Check the connections!
	Conductor/wire breakage.	Check all wires with cable tester!
	Defective measuring device (signal input).	Check the amperemeter (and its fuse) and the analog input of the signal processing unit!
Analog output signal too low:	Load resistance too high.	Check the value of the load resistance!
	Supply voltage too low.	Check the power supply and power /current on the transducer / transmitter!
Slight shift of the output signal:	Diaphragm of the sensor is severely contaminated.	Clean with non-aggressive cleaning solutions, soft brush or sponge.
	Diaphragm of the sensor is calcified or crusted.	It is recommended to clean carefully and remove dirt.
Large shift of the output signal:	Diaphragm of the sensor is damaged (caused by overpressure or mechanically).	Check the diaphragm of the sensor, if it is damaged then send the device back to the manufacturer!

7. MAINTENANCE AND REPAIR

The instrument does not require regular maintenance. The repair will be carried out at the NIVELCO' premises only. When dismantling the device, it must always be done in a depressurized and currentless condition! Also, make sure that the medium is drained off.

After the device has been properly shut down, if necessary, clean the diaphragm carefully with a non-aggressive cleaning solution, soft brush or sponge.

Wrong cleaning or improper touch may cause irreparable damage to the diaphragm. Never use pointed objects or pressured air for cleaning the diaphragm.

Devices for repair should be returned fully cleaned, and disinfected. In addition, a form must be enclosed with the device, declaring that the device is free from all contaminants and substances hazardous to health. The form (B 0407 / C – Returned equipment handling form) can be downloaded from our website: www.nivelco.com.

8. STORAGE CONDITIONS

Storage temperature⁽¹⁾: -40 °C ... +100 °C (-40 °F ... +212 °F)

⁽¹⁾Minimum temperature with PVDF process connection is -30 °C (-22 °F)

drf7612a0600h_04

November 2019

NIVELCO reserves the right to change technical data without notice.