

AQUA PLUS

SWAN-2 190-190S-300-300S

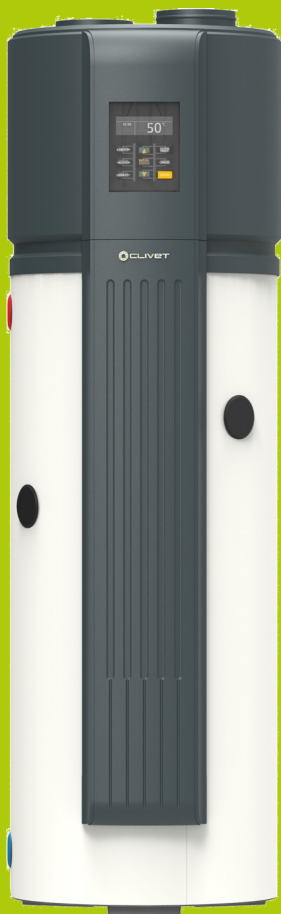

MANUAL

FOR INSTALLATION,
USE AND MAINTENANCE



Dear Customer,

We congratulate you on choosing these product.

Clivet is being working for years to offer systems able to assure the maximum comfort for long time with high reliability, efficiency , quality and safety. The target of the company is to offer advanced systems, that assure the best comfort, reduce the energy consumption, the installation and maintenance costs for all the life-cycle of the system.

With this manual, we want to give you information that are useful in all the phases: from the reception, to the installation and use until the disposal so that a system so advanced offers the best procedure of installation and use.

Best regards and have a nice reading !

CLIVET Spa

The data contained in this manual is not binding and may be changed by the manufacturer without prior notice. All reproduction, even partial, is prohibited. © Copyright - CLIVET S.p.A. - Feltre (BL) - Italia

1	Safety considerations	6
2	Introduction	12
3	Before installation	20
4	Handling	21
5	Selecting the installation site	23
6	Water connections	26
7	Aeraulic connections	32
8	Electrical connections	37
9	Start-up	41
10	Control	47
11	Maintenance	61
12	Residual risks / Decommissioning	66
13	Technical data	70
14	Elfocontrol ³ EVO	81
15	Modbus Protocol	82

Pay particular attention to:



INSTALLER use



USER use

The precautions in this manual are divided as indicated on the side.

They are important, so make sure you follow them closely.

Please read these instructions carefully before installing.

Keep this manual handy for future reference.

This unit contains fluorinated gases. For specific information on gas types and quantities, please refer to the plate found on the unit.

Please contact your dealer for future assistance.



User

CAUTION

- ⇒ *This appliance can be used by children aged from 8 years and above and persons with reduced physical, sensory or mental capabilities or lack of experience and knowledge if they have been given supervision or instruction concerning use of the appliance in a safe way and understand the hazards involved. Children shall not play with the appliance. Cleaning and user maintenance shall not be made by children without supervision.*
- ⇒ *Before cleaning, be sure to stop the operation and turn the breaker off or pull out the power plug.*
- ⇒ *Otherwise, an electric shock and injury may be caused.*

DANGER

- ⇒ *Do not insert fingers, rods or other objects into the air inlet or outlet.*
- ⇒ *When the fan is rotating at high speed, it will cause injury.*
- ⇒ *Do not touch the inner parts of the controller.*
- ⇒ *Do not remove the front panel. Some parts inside are dangerous to touch, otherwise a machine malfunction may be caused.*

Meaning of the symbols DANGER, WARNING, CAUTION and NOTE

DANGER

- ⇒ *It indicates a situation of imminent danger that, if not avoided, will cause death or serious lesions.*

WARNING

- ⇒ *It indicates a potentially dangerous situation that, if not avoided, may cause death or serious lesions.*

CAUTION

- ⇒ *It indicates a potentially dangerous situation that, if not avoided, may cause slight or moderate injury. Also used to warn against unsafe practices.*

NOTE

- ⇒ *It indicates situation that may cause accidental damage to the equipment or property.*

- ⇒ *Never use a flammable spray such as hair spray, lacquer paint near the unit, it may cause a fire.*
- ⇒ *Do not remove, cover or deface any permanent instructions, labels, or the data label from either the outside of the unit or inside of unit panels.*
- ⇒ *It is forbidden the use of the device to children and unassisted disables .*
- ⇒ *It is forbidden to touch the device if you are barefoot and with wet body parts .*
- ⇒ *It is forbidden any cleaning, before having disconnected the device positioning the system main switch on “off”.*
- ⇒ *It is forbidden to pull, remove, twist the electric cables that come out from the device even if it is disconnected from the mains supply.*
- ⇒ *It is forbidden to trample on the device and/ or to put on it any type of object.*
- ⇒ *It is forbidden to throw or spray water directly on the device.*
- ⇒ *It is forbidden to insert sharpened objects by the air return and supply grilles.*
- ⇒ *It is forbidden to open the lids of access to the internal device parts, without having before positioned the main switch of the system on “off”.*
- ⇒ *Do not turn off the power supply.*

WARNING

- ⇒ *If the supply cord is damaged, it must be replaced by the manufacturer or its service agent or a similarly qualified person.*
- ⇒ *The wiring must be performed by professional technicians in accordance with national wiring regulations.*
- ⇒ *A disconnect device for all poles having a separation distance of at least 3 mm across all poles and that a residual current device (RCD) with a power greater than 10mA is incorporated into fixed wiring.*

- ⇒ *System will stop or restart heating automatically. A continuous power supply for water heating is necessary, except service and maintenance.*
- ⇒ *Keep this manual with the wiring diagram in an accessible place for the operator.*
- ⇒ *Children should be supervised to ensure that they do not play with the unit.*
- ⇒ *Note the unit label data so you can provide them at the assistance centre in case of intervention (see "Unit identification" section)*
- ⇒ *Provide a unit notebook that allows any interventions carried out on the unit to be noted and tracked making it easier to suitably note the various interventions and aids the search for any breakdowns.*
- ⇒ *Water temperature over 50°C can cause severe burns instantly or death from scalds.*
- ⇒ *Children, disabled and elderly are at highest risk of being scalded.*
- ⇒ *Feel water before bathing or showering.*
- ⇒ *Water temperature limiting valves are recommended.*
- ⇒ *Ask qualified person for relocating, repairing and maintaining the unit instead of doing by yourself.*

In case of breakdown or malfunction:

- immediately deactivate the unit
- contact a constructor certified assistance service.
- use original spares parts only.

Ask the installer to be trained on:

- start-up / shutdown
- set points change
- standby mode
- maintenance
- what to do / what not to do in case of breakdown



General instructions

Preliminaries

Read carefully the IOM and use the unit strictly according to the instructions in order to avoid personal injuries, damages to the unit, damages to property and litigations.

Our company does not assume any legal liability for any damage caused by improper use of the unit.

The positioning, hydraulic system, refrigerating, electrics and the air duct must be determined by the system designer or by experts and must take into consideration both the decidedly technical requirements as well as any local regulations in act regarding specific authorisations.

Only qualified personnel can operate on the unit, as required by the regulation in force.

Using the unit in case of breakdown or malfunction :

- voids the warranty
- may compromise the safety of the unit
- may increase time and repair costs.

Follow local safety regulations.

Keep packing material out of children's reach it may be dangerous.

Recycle and dispose of packing material in conformity with local regulations.

Risk situations

The unit has been designed and created to prevent injuries to people. During designing it is not possible to plane and operate on all risk situation. Read carefully "Residual risk" section where all situation which may cause damages to things and injuries to people are reported. Installation, starting, maintenance and repair required specific knowledge; if they are carried out by inexperienced personnel, they may cause damages to things and injuries people.

Intended use

Use the unit only: domestic hot water heating, within limits defined in the technical bulletin and on this manual.

Any use other than intended does not involve the manufacturer in any commitment or obligation.

Hydraulic system

Components

Selection and installation of system components must be carry out by installer.

Water quality

The water quality is determined by the following factors, avoid therefore:

- Inorganic salts
- pH
- Biological load (seaweeds etc)
- Suspended solids
- Dissolved oxygen

Water with inadequate characteristics can cause:

- pressure drop increase
- energy efficiency decrease
- corrosive symptom increase

Risk of freeze

If the unit or the relative water connections can be subject to temperatures close to 0°C adopt measures for prevent risk of freeze.

The appliance is intended to be permanently connected to the water mains and not connected by a hose-set .

The water may drip from the discharge pipe of the pressure-relief device and that this pipe must be left open to the atmosphere.

The pressure-relief device is to be operated regularly to remove lime deposits and to verify that is not blocked.

A discharge pipe connected to the pressure-relief device is to be installed in a continuously downward direction and in a frost-free environment.

Electric system

The characteristics of the electrical lines must be determined by specialized personnel able to design electrical installations; moreover, the lines must be in conformity with regulations in force. Operate in compliance with safety regulations in force .

This unit is required reliable earthing before usage, otherwise might cause death or injury. If you can't make sure that your house power supply is earthed well, please don't install the unit if it does not in conformity with regulations in force.

The power supply should be an independent circuit with rated voltage.

Power supply circuit should be earthed effectively. Do not use water pipes to earthing connection of the unit

Use single protection devices : gloves, glasses ecc.

The power cables and the protection cable section must be defined in accordance with the characteristics of the protections adopted. The serial number label reports the unit specific electrical data, included any electrical accessories.

Connection

All electrical operations should be performed by trained personnel having the necessary requirements by the regulations in force and being informed about the risks relevant to these activities. Refer to the unit electrical diagram (the number of the diagram is shown on the serial number label). Verify that the network has characteristics conforming to the data shown on the serial number label .

Make sure that the unit supply line is selected at start.

Shelter the cables using adequate measure fairleads.



Before starting work, verify that the sectioning device at the start of the unit power line is open, blocked and equipped with sign warning.

First create the earthing connection.

After wire connection, check it again and make sure the correctness before power on.

Prior to powering the unit ensure that all the protections that were removed during the electrical connection work have been restored.

Signal lines/data-lay

Do not overpass the maximum power allowed, which varies, according to the type of signal.

Lay the cables far from power cables or cables having a different voltage and that are able to emit electromagnetic disturbances. Do not lay the cable near devices which can generate electromagnetic interferences.

Do not lay the cables parallel to other cables; cable crossings are possible, only if laid at 90°.

Connect the screen to the ground, only if there aren't disturbances .

Guarantee the continuity of the screen for the entire extension of the cable.

Respect impedance, capacity and attenuation indications.

Modification

All unit modifications will end the warranty coverage and the manufacturer responsibility.

Breakdown/Malfuction

Disable the unit immediately in case of breakdown or malfunction.

Contact a constructor certified assistance service.

Use original spares parts only.

User training

The installer has to train the user on :

- ON / OFF
- set points change;

- standby mode;
- maintenance;
- what to do / what not to do in case of breakdown.

Data update

Continual product improvements may imply manual data changes

Visit manufacturer web site for updated data.

Safety

Operate in compliance with safety regulations in force .
Use single protection devices: gloves, glasses, helmet etc.

NOTE

⇒ *Before beginning the work, ensure you that have the final project for installing the aeraulic, hydraulic, electric,drains and positioning the units.*

Unit identification

The serial number label is positioned on the unit and allows to indentify all the unit features.

The matriculation plate shows the indications foreseen by the standards, in particular:

- unit type
- serial number (12 characters)
- year of manufacture
- wiring diagram number
- electrical data
- type of refrigerant
- refrigerant charge
- manufacturer logo and address

The matriculation plate must never be removed.

It contains fluorinated greenhouse gases.

Serial number

It identifies uniquely each unit.

Must be quoted when ordering spare parts.

Assistance request

Note data from the serial number label and write them in the chart on side, so you will find them easily when needed.

Recommended instruments

Set of Philips and flathead screwdrivers;

Cutters;

Drill;

Scissors;

Set of open spanners or pipe wrenches;

Range;

Hydraulic material for the sealing of the threads;

Electrical equipment for the connections;

Cut prevention gloves;

Tester and amperometric pliers.

Before requesting start-up

- Completed aeraulic system and free of dirt
- Completed water system, circuit loading and venting



Pay particular attention to:

⇒ warnings / prohibitions / danger indicating particularly important operations or information, operations that cannot be done, which compromise the functionality of the unit or which may cause damage to things or persons.

Serie
Size
Serial number
Year of manufacture
Wiring diagram

- Discharges unit connected
- Electric connections

Repair parts

When ordering repair parts please always give the following information:

Model, serial and product number.

Parts name.

Picture

All the picture in this manual are for explanation purpose only. They may be slightly different from the unit you purchased (depend on model). Please refer to the real sample instead of the picture of this manual.

2 INTRODUCTION

Parts unit - 190

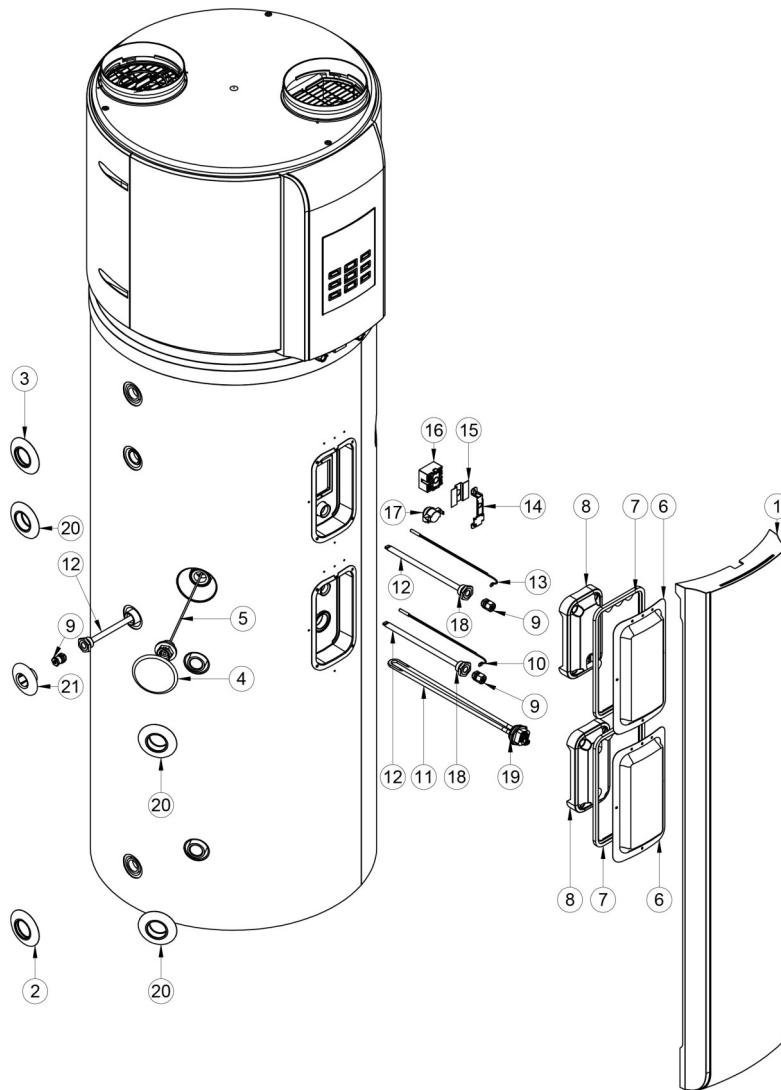

N.	Code	Description
1	C63910100	FRONTAL COVER BLACK
2	C63910129	INLET WATER COVER 3/4"
3	C63910130	OUTLET WATER COVER 3/4"
4	C63810064	BLACK COVER FOR ANODE
5	C96300002	ANODE 3/4"
6	C63910111	WHITE COVER FOR HEATER AND THERMOSTATS
7	C63910099	GASKET FOR HEATER AND THERMOSTATS COVER
8	C63910094	PE ENCLASURE
9	C95110067	CABLE GLAND PG7
10	C51110008	NTC PROBE 3 POLES

11	C87310017	ELECTRICAL HEATER
12	C75410119	PROBE HOLDER
13	C51110007	NTC PROBE 2 POLES
14	C63910092	THERMOSTAT HOLDER
15	C63910098	SAFETY COVER FOR THERMOSTAT
16	C95710074	THERMOSTAT WKQ-66T-L85C MANUAL RESET
17	C95710075	THERMOSTAT WKQ-60T01-L78-10C AUTOMATIC RESET
18	C63810057	GASKET FOR PROBE HOLDER
19	C63810058	GASKET FOR HEATER
20	C63910149	SOLAR CONNECTION COVER
21	C63910150	SOLAR PROBE COVER

The codes are subject to being updated: contact the authorised service centre for the updated code

Parts unit - 190

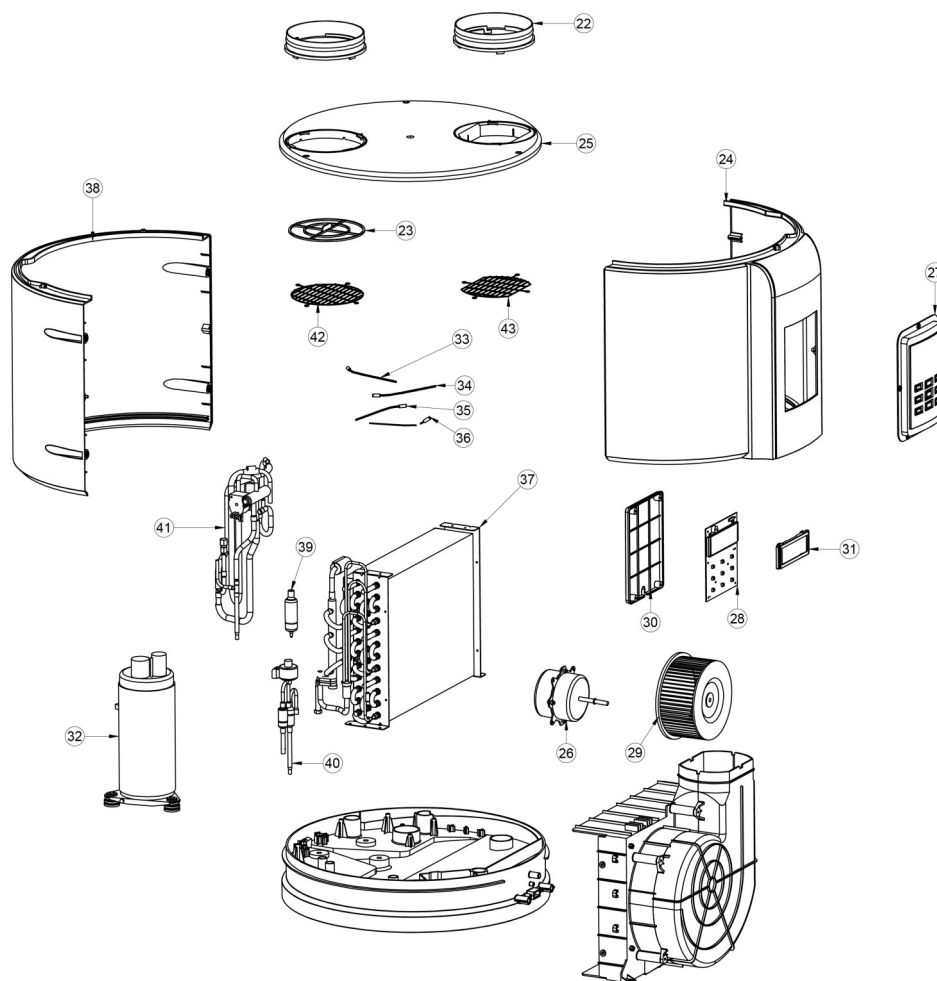

N.	Code	Description
20	12125300001201	DUCT RING
21	201190590315	INLET AIR FILTER
22	12125300001210	FRONT COVER, UP
23	12125300001203	TOP COVER
24	11002012003645	FAN MOTOR
25	12125300002380	DISPLAY PANEL
26	17125300003923	DISPLAY BOARD ASSEMBLY
27	12100103000136	FAN IMPELLER
28	12125300000222	DISPLAY COVER
29	201190590324	LENS HOOD
30	11103010000228	FIXED SPEED ROTARY COMPRESSOR

31	11201007002462	DISCHARGE TEMPERATURE SENSOR
32	11201007000063	ROOM TEMPERATURE SENSOR
33	11201007000328	SUCTION PIPE TEMPERATURE SENSOR
34	11201007001782	COIL PIPE TEMPERATURE SENSOR
35	201590590043	EVAPORATOR ASSEMBLY
36	12125300001220	REAR COVER UP
37	201600900702	DRY FILTER
38	201690590884	EXPANSION VALVE ASSEMBLY
39	201600630576	FOUR-WAY VALVE
40	201290590261	WIRE NET
41	201290590169	WIRE NET

The codes are subject to being updated: contact the authorised service centre for the updated code

Parts unit - 190

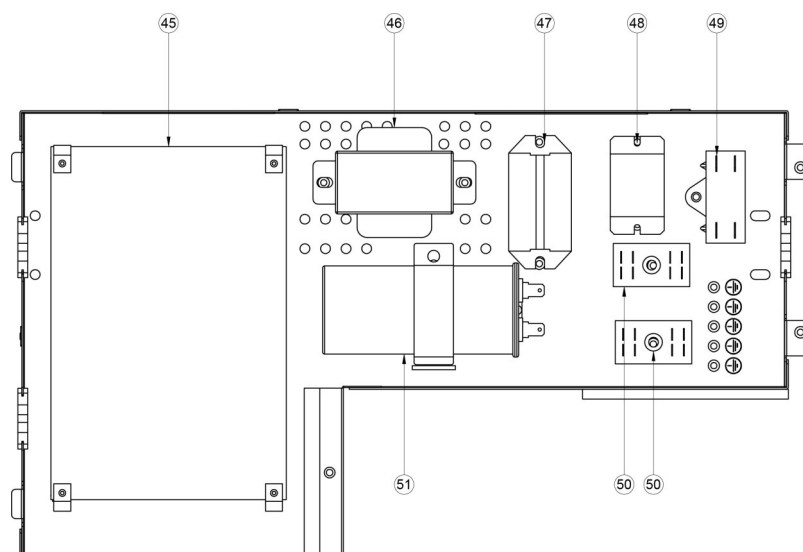

N.	Code	Description
45	17125300004103	OUTDOOR MAIN CONTROL BOARD ASSEMBLY
46	202300930280	LINEAR TRANSFORMER
47	202300830544	DUAL RELAY
48	11203401000039	RELAY
49	202401100964	CAPACITOR
50	202301400220	WIRE JOINT
51	202401000888	CAPACITOR

The codes are subject to being updated: contact the authorised service centre for the updated code

2 INTRODUCTION

Parts unit - 300

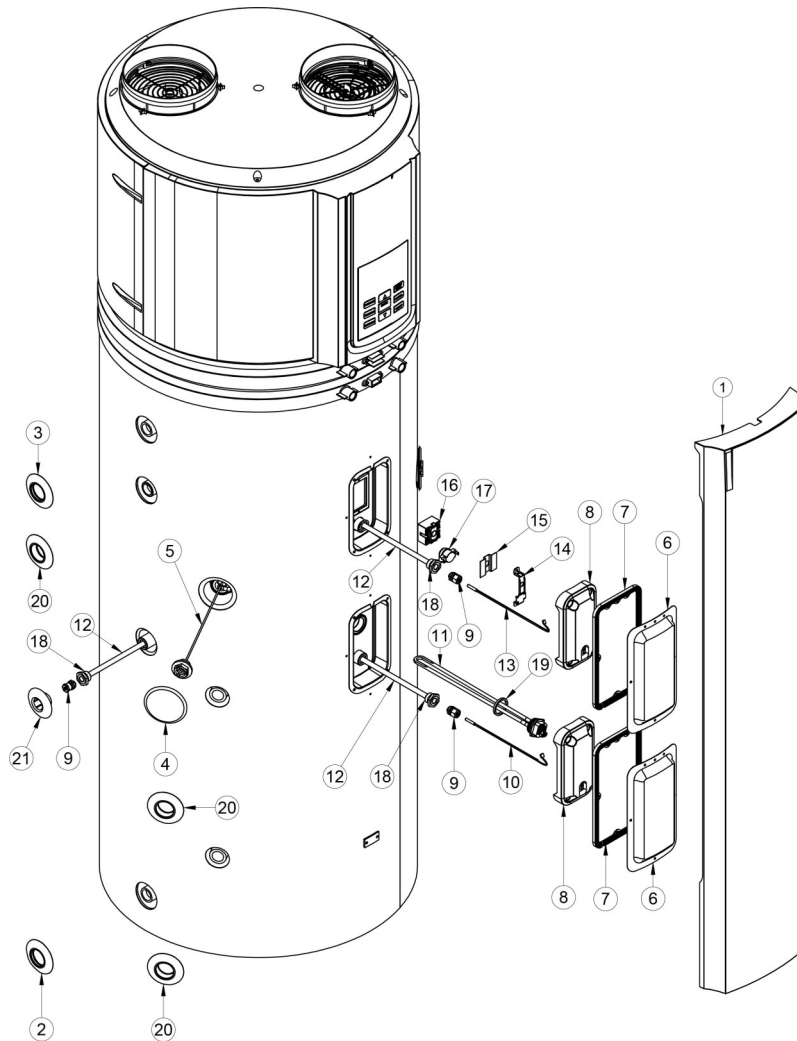

N.	Code	Description
1	C63910095	FRONTAL COVER BLACK
2	C63910129	INLET WATER COVER 3/4"
3	C63910130	OUTLET WATER COVER 3/4"
4	C63810064	BLACK COVER FOR ANODE
5	C96300003	ANODE 3/4"
6	C63910111	WHITE COVER FOR HEATER AND THERMOSTATS
7	C63910099	GASKET FOR HEATER AND THERMOSTATS COVER
8	C63910094	PE ENCLASURE
9	C95110067	CABLE GLAND PG7
10	C51110008	NTC PROBE 3 POLES

11	C87310017	ELECTRICAL HEATER
12	C75410119	PROBE HOLDER
13	C51110007	NTC PROBE 2 POLES
14	C63910092	THERMOSTAT HOLDER
15	C63910098	SAFETY COVER FOR THERMOSTAT
16	C95710074	THERMOSTAT WKQ-66T-L85C MANUAL RESET
17	C95710075	THERMOSTAT WKQ-60T01-L78-10C AUTOMATIC RESET
18	C63810057	GASKET FOR PROBE HOLDER
19	C63810058	GASKET FOR HEATER
20	C63910149	SOLAR CONNECTION COVER
21	C63910150	SOLAR PROBE COVER

The codes are subject to being updated: contact the authorised service centre for the updated code

2 INTRODUCTION

Parts unit - 300

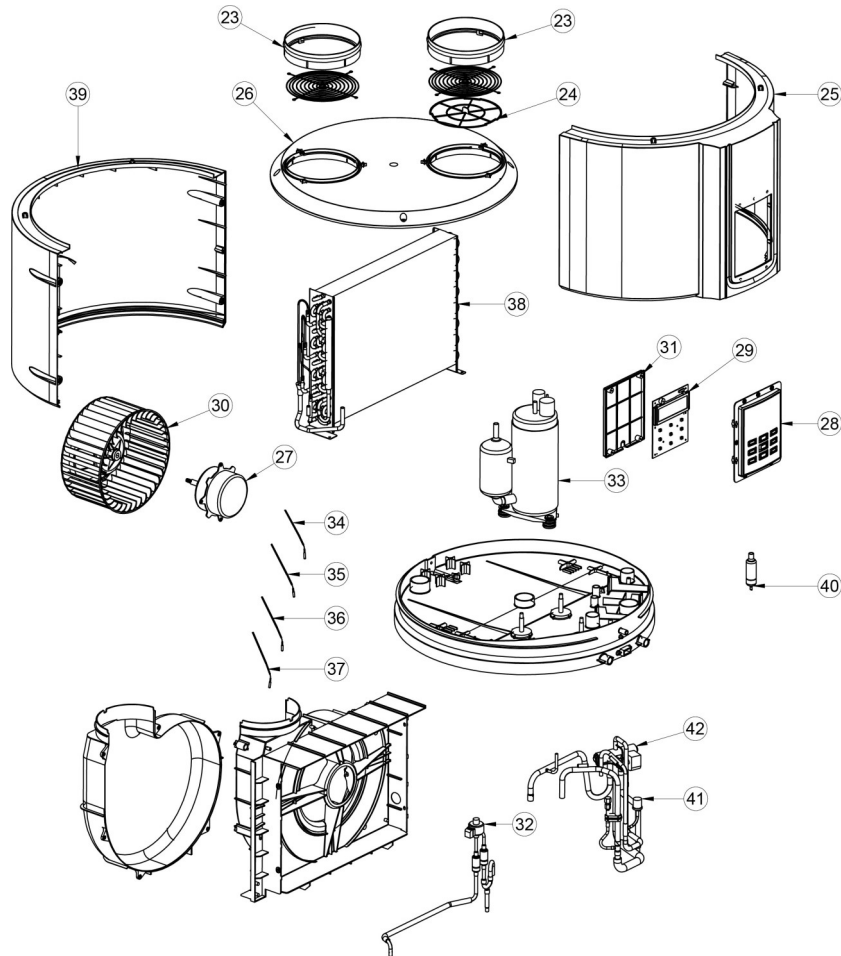

N.	Code	Description
23	12125300000182	DUCT RING
24	12125300000197	INLET AIR FILTER
25	12125300000214	FRONT COVER, UP
26	12125300000052	TOP COVER
27	11002012001785	FAN MOTOR
28	121253000002381	DISPLAY PANEL
29	171253000003923	DISPLAY BOARD ASSEMBLY
30	12100103000158	FAN IMPELLER
31	12125300000221	DISPLAY COVER
32	154253000002020	EXPANSION VALVE ASSEMBLY
33	11103010001963	FIXED SPEED ROTARY COMPRESSOR

34	11201007002463	DISCHARGE TEMPERATURE SENSOR
35	11201007000063	ROOM TEMPERATURE SENSOR
36	11201007000164	SUCTION PIPE TEMPERATURE SENSOR
37	11201007001784	COIL PIPE TEMPERATURE SENSOR
38	15825300000820	EVAPORATOR ASSEMBLY
39	12125300000058	REAR COVER UP
40	15500504000090	DRY FILTER
41	17400516000065	PRESSURE SWITCH
42	15500216001121	FOUR-WAY VALVE KIT

The codes are subject to being updated: contact the authorised service centre for the updated code

Parts unit - 300

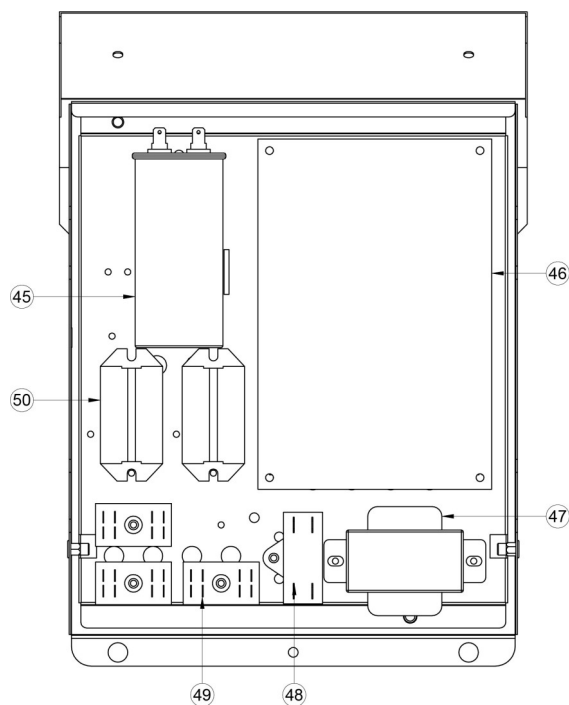

N.	Code	Description
45	17400103000153	COMPRESSOR CAPACITOR
46	17125300004103	OUTDOOR MAIN CONTROL BOARD ASSEMBLY
47	11203103000150	LINEAR TRANSFORMER
48	17400101000024	FAN MOTOR CAPACITOR
49	17400401000194	TERMINAL BLOCK, 2P
49	17400401000012	WIRE JOINT
50	11203401000039	RELAY

The codes are subject to being updated: contact the authorised service centre for the updated code



Reception

Before accepting the delivery you have to check:

- that the unit hasn't been damaged during transport.
- check that the materials delivered correspond with that indicated on the transport document comparing the data with the identification label positioned on the packaging.

In case of damage or anomaly:

- Write down on the transport document the damage you found and quote this sentence: "Conditional acceptance clear evidence of deficiencies/damages during transport".
- Contact supplier and the carrier by fax and registered mail with advice of receipt.

NOTE

⇒ *Any disputes must be made within the 8 days following the delivery. Complaints after this period are invalid.*



A - Use protection to avoid the unit damaging

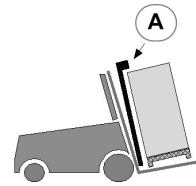



Handling

- ⇒ Check that all handling equipment complies with local safety regulations (cran, forklifts, ropes, hooks, etc.).
- ⇒ Provide personnel with personal protective equipment suitable for the situation, such as helmet, gloves, accident-prevention shoes, etc.
- ⇒ Observe all safety procedures in order to guarantee the safety of the personnel present and the of material.

Lifting

- A. Verify unit weight and handling equipment lifting capacity.
- B. Identify critical points during handling (disconnected routes, flights, steps, doors).
- C. Stair climbing trolley.
Handle the packed unit
- D. Minimum passage height
- E. During transport, the unit cannot be inclined more than 30°.

NOTE

- ⇒ This unit is heavy, it need to be carried by two or more persons, otherwise might cause injury and damage.
- ⇒ No contact of fingers and other things with the vanes.

CAUTION

- ⇒ If the unit has been tipped during transport, wait at least 2 hours before starting it up

Shipped unit weighs

Std unit		
190	kg	114
300	kg	138

Unit with solar		
190S	kg	131
300S	kg	158

A



B

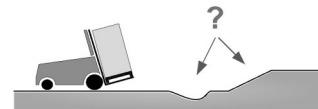

C



D

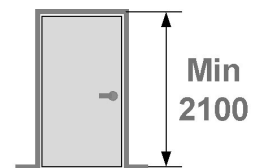

E

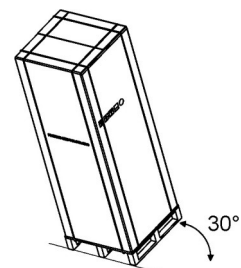

4 HANDLING



Packaging removing

Be careful not to damage the unit.

Keep packing material out of children's reach it may be dangerous.

Recycle and dispose of the packaging material in conformity with local regulations.

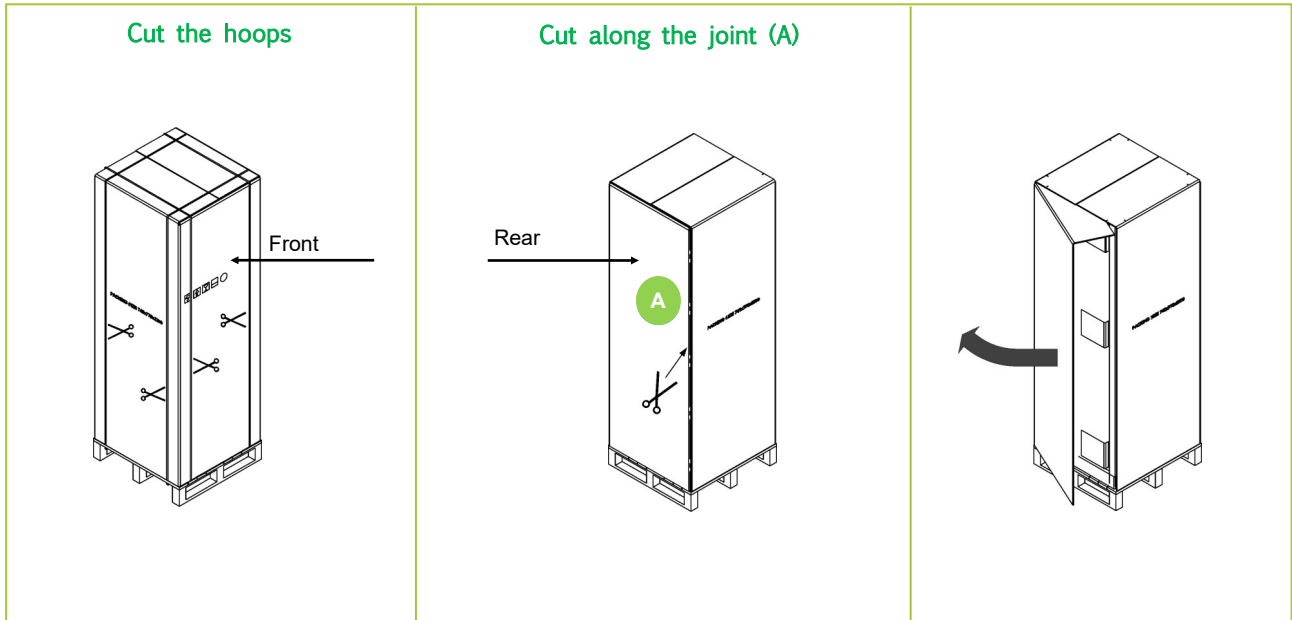

Handle for handling

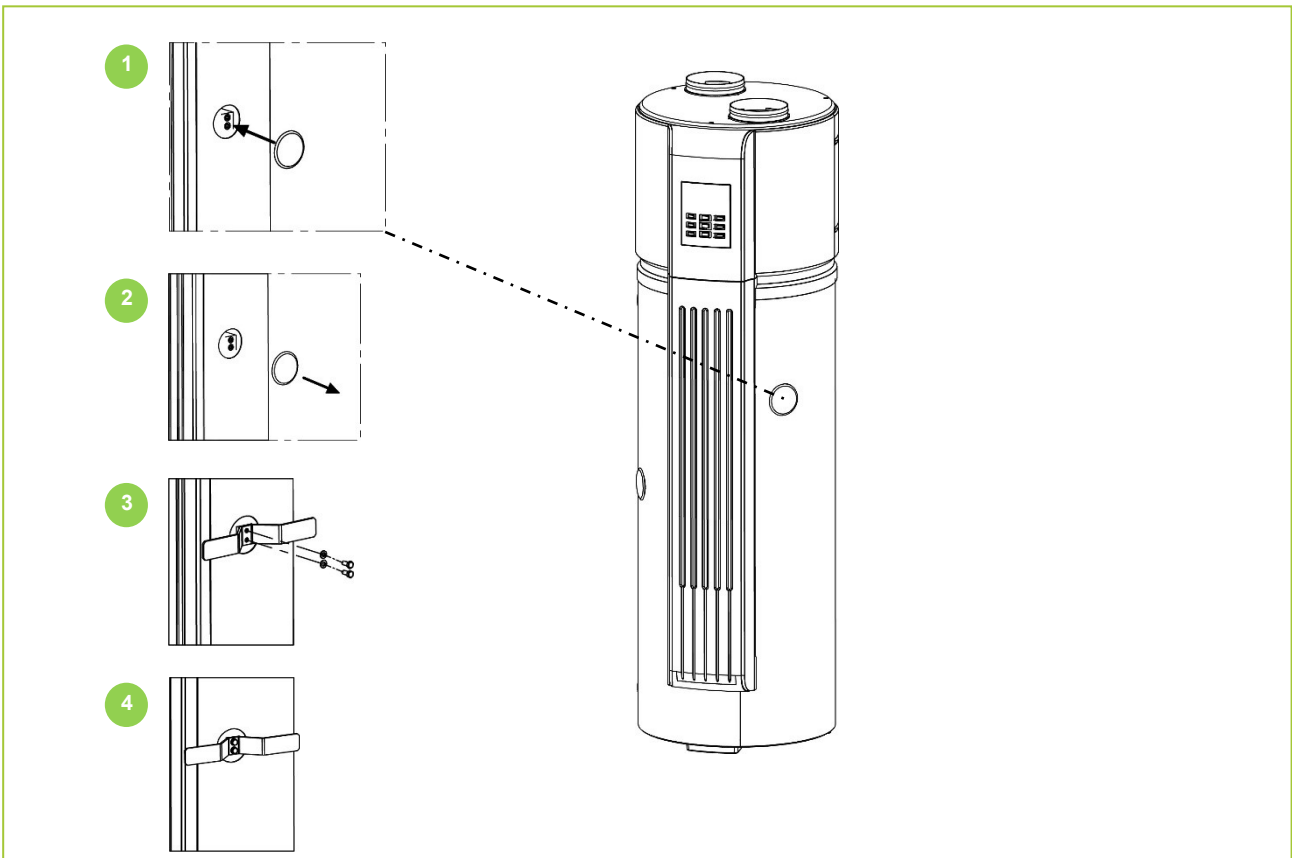



The installation has been implemented by qualified technical personnel only and that the instructions contained in the present manual and the local regulations in force have been adhered to.

Choose the installation place according to the following criteria:

- customer approval
- Internal
- in a dry room/compartment where the temperature cannot fall below 0 degrees
- guarantee good unit operation
- safe accessible position
- enough space for installation and maintenance shall be preserved.
- the air inlet and outlet should be free from obstacles and strong wind.
- the base surface should be flat, able to bear the weight of the unit and suitable for installing the unit without increasing noise or vibration.
- the operation noise and air flow expelled shall not affect neighbors.
- If the unit has to be installed on a metal part of building, make sure the well electric insulation which should meet the relevant local electric standard.
- use of air from heated rooms could penalise the heating performance of the building
- the unit must be securely fixed, otherwise, noise and shaking may be resulted.
- make sure that there's no obstacle around the unit.

NOTE

- ⇒ *The external air temperature must also be considered when installing this unit, in heat pump mode the external air temperature must be above -7°C and below 43°C.*
- ⇒ *If the external air temperature falls outside these upper and lower limits, the electrical elements will be activated to meet the hot water demand and the heat pump does not operate.*
- ⇒ *The unit should be located in an area not subject to freezing temperatures. T*
- ⇒ *he unit located in unconditioned spaces (i.e., garages, basements, etc.) may require the water piping, condensate piping, and drain piping to be insulated to shelter against freezing.*



NOTE

Installing the unit in any of the following places may lead to malfunction:

- The site contains mineral oils such as cutting lubricant
- Seaside where the air contains much salt.
- Hot spring area where corrosive gases exist, e.g., sulfide gas.
- Factories where the power voltage fluctuates seriously.
- The place with direct sunlight and other heat supplies. If there's no way to avoid these, please install a covering.
- Place like kitchen where oil permeates.
- Place where strong electromagnetic waves exist.
- Place where flammable gases or materials exist.
- Place where acid or alkali gases evaporate.

Consider sound emission

Noise levels could represent an inconvenience if installed in areas that require extreme silence, example near bedrooms

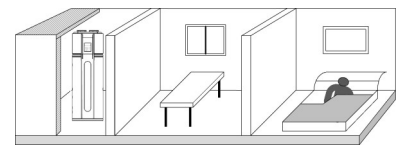
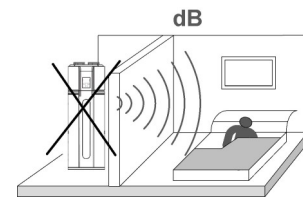

Functional spaces

Unit		190	300
Diameter	A	560	650

If installed in inclosed space

The unit must be located in a space $>15\text{m}^3$, and must have unrestricted air flow.

Make sure there is enough Installation space.

For optimal efficiency and serviceability, the following clearances should be maintained:

- 400mm on the air inlet side;
- 400mm on the air outlet side;
- 600mm in the back;
- 600mm in the front.

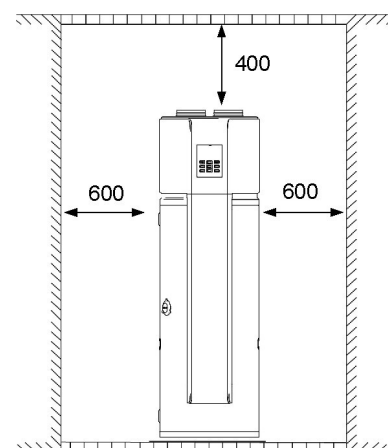
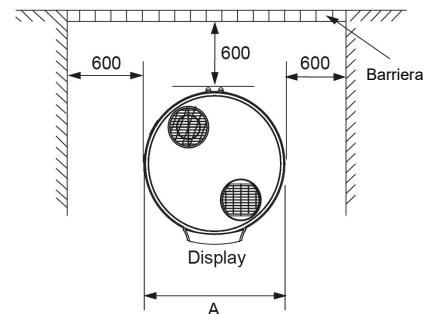



NOTE

- ⇒ Install the unit in the indoor space, it is not allow to install the unit at the rainy space
- ⇒ In case of rain entering to internal components of the unit, the component might be damaged or causing physical danger.

Check that the floor can support the weight of the unit in operation (dimensional see)

Unit in bubble level

Electrical outlet

The installation height of power supply should be over 1.5m, if separate the power supply from water.
 Configuration for electric power socket (schuko + On/Off switch) close to the unit
 The plug must be accessible at all moment.

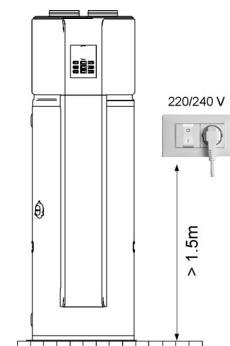
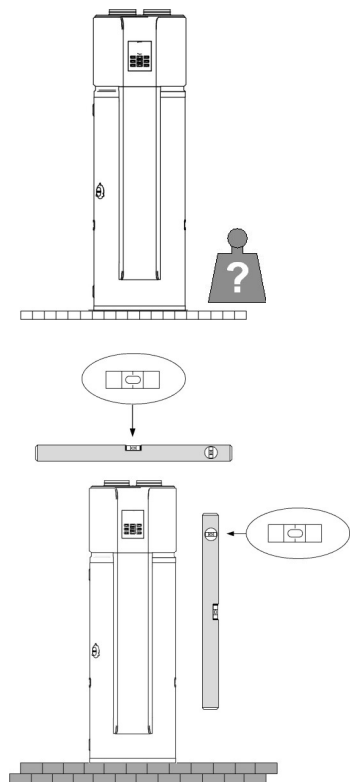
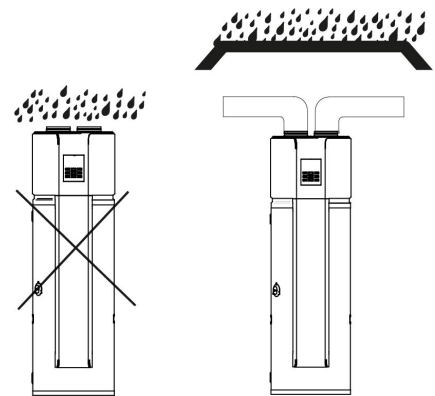



Water feature

Note

- ⇒ Fill the storage tank (DHW) only during the unit start-up.
- ⇒ If the house is not immediately lived, or the unit is turned off for long periods, empty the storage tank to avoid the stagnation of the water, or with temperatures close to 0°C the risk of freeze.

See the Maintenance section for drain.

Water features

- confirming to local regulations
- Langelier (L_L) index between 0 and +0.4
- within the limits indicated by table

The water quality must be checked by qualified personnel.

Hardness

If necessary, fit a water softener to reduce water hardness.

Cleanliness

Before connecting the water to the unit, clean the system thoroughly with specific products effective to remove residues or impurities that may affect functioning.

Existing systems must be free from sludge and contaminants and protected against buildups.

New systems

In case of new installations, it is essential to wash the entire installation (with the circulator uninstalled) before commissioning the central installation.

This removes residues of the installation process (welding, waste, joint products...).

The system must then be filled with clean high-quality tap water.

Existing systems

If a new unit is installed on an existing system, the system must be rinsed to avoid the presence of particles, sludge and waste.

The system must be drained before installing the new unit.

Dirt can be removed only with a suitable water flow.

Each section must then be washed separately.

Particular attention must also be paid to “blind spots” where a lot of dirt can accumulate due to the reduced water flow.

The system must then be filled with clean high-quality tap water.

If, after rinsing, the quality of the water is still unsuitable, a few measures must be taken to avoid problems.

An option to remove pollutants is to install a filter.

The warranty does not cover damages caused by limestone formations, deposits and impurities from the water supply and/or from failure to clean the systems.

Water component for corrosion limit on Copper

PH	7,5 ÷ 9,0	
SO ₄ ⁻	< 100	
HCO ₃ ⁻ / SO ₄ ⁻	> 1	
Total Hardness	8 ÷ 15	°f
Cl ⁻	< 50	ppm
PO ₄ ³⁻	< 2,0	ppm
NH ₃	< 0,5	ppm
Free Chlorine	< 0,5	ppm
Fe ₃ ⁺	< 0,5	ppm
Mn ⁺⁺	< 0,05	ppm
CO ₂	< 50	ppm
H ₂ S	< 50	ppb
Temperature	< 65	°C
Oxygen content	< 0,1	ppm
Sand	10 mg/L 0.1 to 0.7mm max diameter	
Ferrite hydroxide Fe ₃ O ₄ (black)	Dose < 7.5 mg/L 50% of mass with diameter < 10 µm	
Iron oxide Fe ₂ O ₃ (red)	Dose < 7.5mg/L Diameter < 1 µm	



Pipes connections

Connect the water outlet/inlet using pipes and couplings that are resistant to both the operating pressure and the hot water temperature, which can reach 70°C.

Note

- ⇒ Do not use materials that cannot withstand high temperatures
- ⇒ Do not use flexible pipes for unit connection.

Dielectric joints (Provided by the customer)

In order to prevent the formation of galvanic couples between iron/copper (risk of corrosion), do not connect the domestic hot water connection directly to the copper pipes.

Install a dielectric joint on the domestic hot water inlet and outlet pipes

Note

- ⇒ The above devices must be installed downstream of the product, before hydraulic shut-offs, and said devices must not be hydraulically shut-off either.

Water filter (Provided by the customer)

⇒ The filter is extremely important: it helps to lockout any impurities in the water and avoid clogging the system and heat exchanger.

⇒ It must be installed immediately at the entrance to the water mains, in a position that is easily accessible for cleaning.

⇒ The filter should never be re-moved.

Pressure reducer (Provided by the customer)

If the inlet water pressure is less than 0,2MPa (2bar), a pump should be installed at the water inlet.

For guarantee the safety usage of storage tank at the condition of water supply hydraulic higher than 0,65MPa (6,5bar), a pressure reducer should be installed at the water inlet pipe

⇒ A calibration pressure of 3-4 bar (0,3-0,4 MPa) is advisable.
Periodically check the pressure

Expansion vessel (Provided by the customer)

Be provided with an expansion tank proportioned to the boiler's dimensions (you are advise to let the circulation be made by a thermo technician).

To compensate the pressure variations and/or the water hammers in the cold water network and to avoid water losses, it is recommended to install an expansion vessel

An expansion tank allows the correct system pressure to be maintained when the water temperature varies.

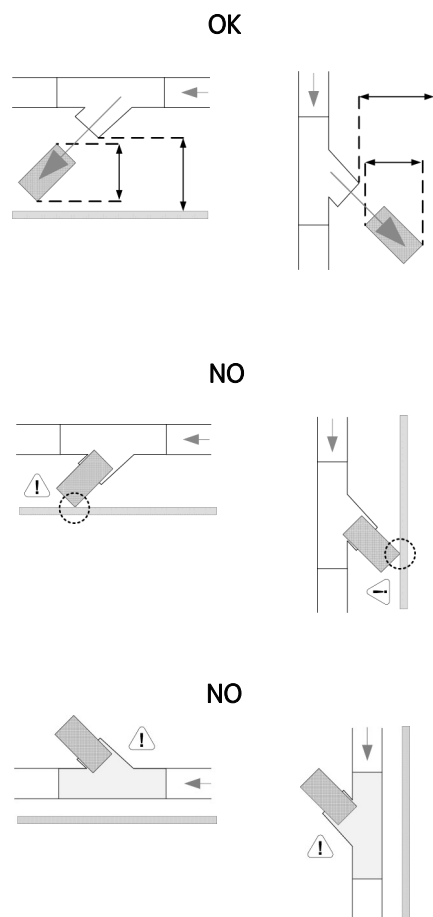



Safety valve (Provided by the customer)

Install all safety devices required by the local laws in force in the countries where the unit is installed.

The manufacturer of the heat pump shall not be held responsible for any damage caused by failure to comply with said laws.

⇒ *Install the safety valve (7 Bar max) (0,7 MPa max) on the outlet of the domestic hot water, which must be connected to a suitable discharge. If this is not done and the valve trips and the room is flooded, the manufacturer of the heat pump shall not be held responsible.*

The discharge pipe connected to the safety valve must be installed and angled downwards to an adequate drain and sheltered from freezing.

The pressure-relief device is to be operated regularly to remove lime deposits and to verify that is not blocked.

See Maintenance section.

To the installation information refer to: Water system piping



Hydraulic connections

STD unit		Unit with solar	
A	DHW outlet	A	DHW outlet
B	Aqueduct inlet	B	Aqueduct inlet
		C	DWH recirculation
		D	Solar outlet
		E	Solar inlet
Electrical connections → page 79			

Connecting drains (STD unit /Solar)

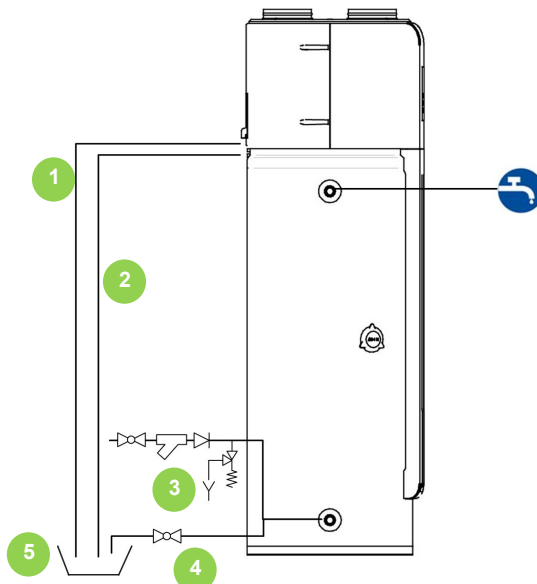

1	Upper condensate outlet ø 10
2	Condensate drain ø 10
3	Safety valve
4	Storage tank discharge
5	Drain accumulation / drain pit



Condensate drain

The condensate must be disposed in order to avoid damages to people and things.

To smoothly drain condensate, the unit should be installed at a horizontal floor. Otherwise, the drain vent is ensured at the lowest place.

Note

- ⇒ Condensate drain lines installed and piped to an adequate drain accumulation /drain pit.
- ⇒ Arrange the drain pipe to ensure smooth draining.
- ⇒ Improper drainage work may cause wetting of the building, furniture etc..
- ⇒ **IMPORTANT:** Water coming from the plastic shroud is an indicator that both condensation drain lines (1,2) may be blocked
- ⇒ Immediate action is required.
- ⇒ A discharge pipe connected to the pressure-relief (3) device is to be installed in a continuously downward direction and in a frost-free environment

Note

- ⇒ Condensate can escape from unit if drainage pipe is blocked.
- ⇒ If the drainage pipe is blocked, consider installing a condensate collection tray.

Block the condensate drain pipe with the clip supplied.

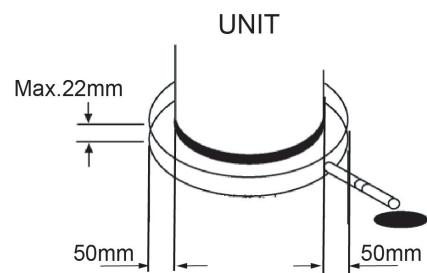
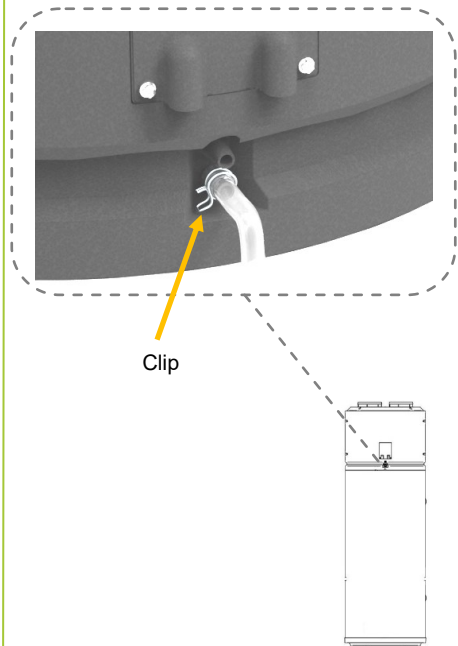



Water system

Note

⇒ In case of installing the unit at a place where outside temperature below freezing point, insulation must be provided for all hydraulic components.

STD unit

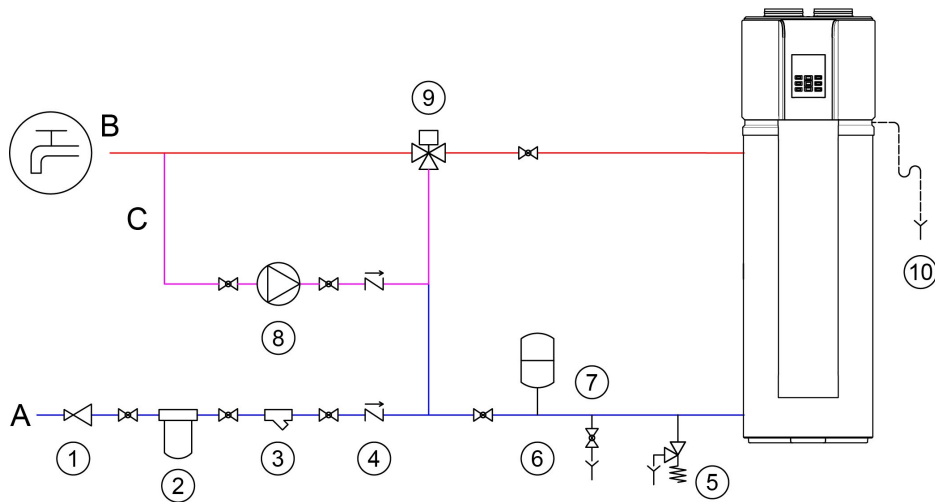

Indicative plumbing diagram

The system components must be defined by Designer and Installer (ex. expansion tanks, vents, taps, calibration/safety valves etc.)

1	Pressure reducing valve	2	Water treatment devices (water softener, etc.)	3	Filter Y
4	Non-return valve	5	Safety valve with discharge	6	DHW expansion vessel
7	Storage drain	8	Hot water circulator (recirculation) with check valve	9	Mixing valve thermostatic
10	Condensate drain	A	Aqueduct inlet	B	DHW
C	DHW recirculation				

Note

⇒ Water temperature limiting valve is recommended for mixing the inlet cold water with outlet hot water to prevent burns caused by hot water

⇒ Do not use flexible pipes for unit connection.

6 WATER CONNECTIONS



Unit with solar

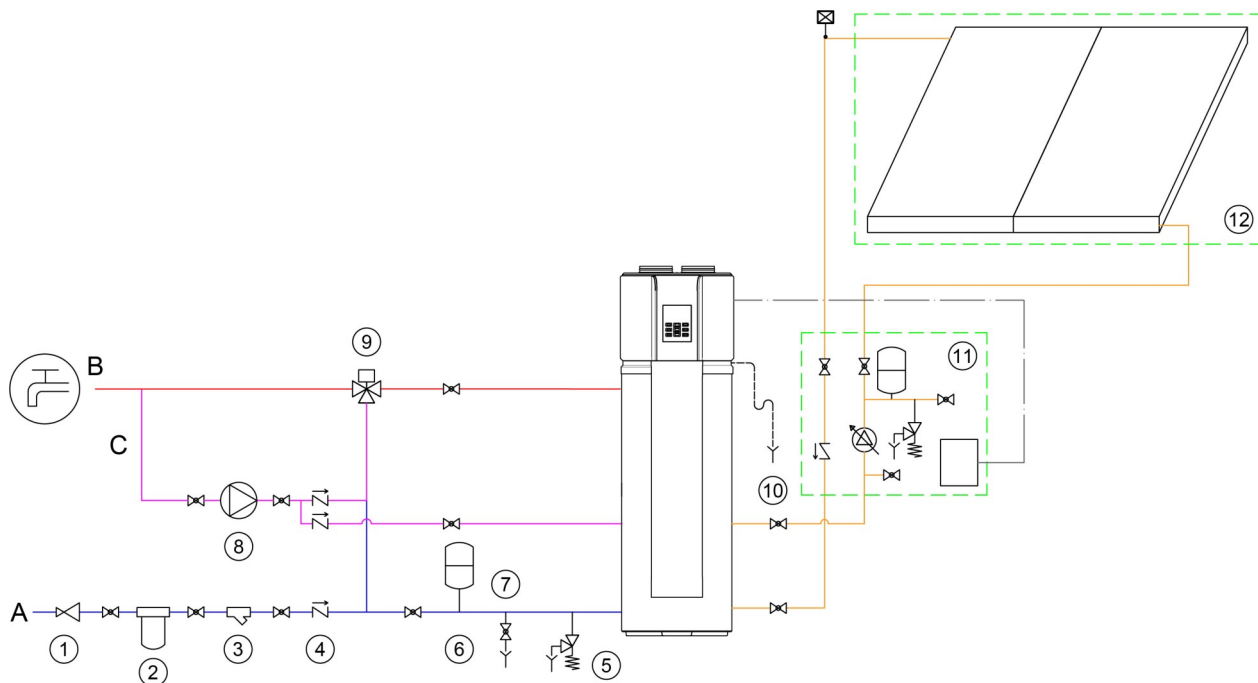

Indicative plumbing diagram

The system components must be defined by Designer and Installer (ex. expansion tanks, vents, taps, calibration/safety valves etc.)

1	Pressure reducing valve	2	Water treatment devices (water softener, etc.)	3	Filter Y
4	Non-return valve	5	Safety valve with discharge	6	DHW expansion vessel
7	Storage drain	8	Hot water circulator (recirculation) with check valve	9	Mixing valve thermostatic
10	Condensate drain	11	Solar circulation unit (not supplied)	12	Solar panels (not supplied)
A	Aqueduct inlet	B	DHW	C	DHW recirculation

Note

⇒ Water temperature limiting valve is recommended for mixing the inlet cold water with outlet hot water to prevent burns caused by hot water

⇒ Do not use flexible pipes for unit connection.



Possible installations

The unit must be installed inside the building, preferably in a technical room or a laundry room or a garage. At any rate, it is always preferable to avoid installing the unit near bedrooms or in rooms that must be protected from noise.

Outdoor installation is prohibited, as well as installation in places subject to external weather.

Examples below refer to the 190 version. For the 300 version, the expulsion and intake connections are inverted.

INTAKE AND EXPULSION DUCTS (recommended)

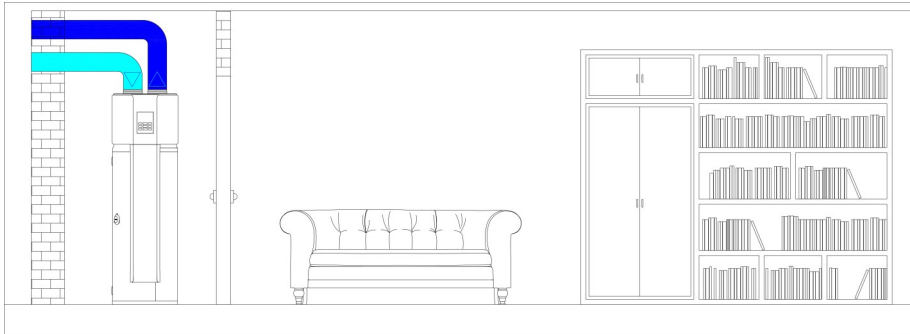

Channelling the intake and expulsion through ducts allows the unit to function with air taken from outside the house. Heat is extracted from the outdoor air, and used as a source for the heat pump.

Later this same air is expelled outside the building.

Therefore, unit operation does not cause an increase in heating requirements in the home. It is necessary to fit the system with correctly sized pipes in relation to the available pressure head supplied by the unit.

INTAKE DUCTS (conditioned)



Installation with an intake duct and free expulsion is recommended if there is a desire to use the air expelled by the unit, cold dehumidified air (5-10°C colder than the intake air), to cool the room.

The unit must be installed preferably in a room that does not require heating, because the unit releases cold air into the environment and it would increase the cost of heating that room.

The unit must be installed in a room with a minimum volume greater than 15m². The expulsion air flow must be guaranteed and cannot be blocked. It is necessary that the vents be correctly sized.

EXPULSION DUCTS (conditioned)

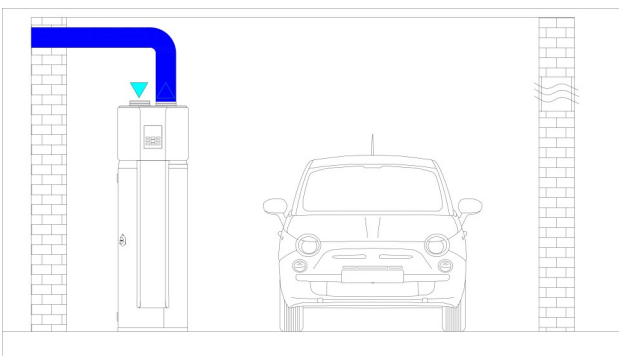

In this particular type of installation, the unit takes in air from the room where it is installed, extracts the heat and then expels that air outside the house.

The unit must be installed in a room with suitable openings to allow the correct flow of air into the unit, which would prevent the air pressure in the room from falling. The unit must be installed in a room with a minimum volume greater than 15m².



Aeraulic design criteria

The dimensioning and the correct execution of the aeraulic connections are critical to ensure the unit operating and an appropriate level of quietness in the served area.

Pressure loss in the duct will reduce the air flow, which can cause a reduction in efficiency of the unit.

Air duct connection

Note

⇒ If the duct outlets for the outdoor air inlet and exhaust are outside of coverage, must end with a 90 ° bend downward, to prevent entry of water from the air inlet.

To perform the ductings:

- ⇒ Connect the ductings fixing them to the connections with the special hookings to the circular flanges.
- ⇒ The duct weight should not lie on the connection flanges.
- ⇒ Put antivibration joints between ducts and units.
- ⇒ The connection to the flanges and among the different duct sections must guarantee the air seal, avoiding air dispersions in supply and return that penalize the overall efficiency of the installation.
- ⇒ Limit the pressure drops by optimizing the path, the type and the number of curves and branches.
- ⇒ Use curves of large radius.
- ⇒ For unit air outlet with duct, when unit operating, condensate will be generated around outside of duct.
- ⇒ Thermically insulate the supply ducts to avoid heat losses and condensate.

Unit attacks 190

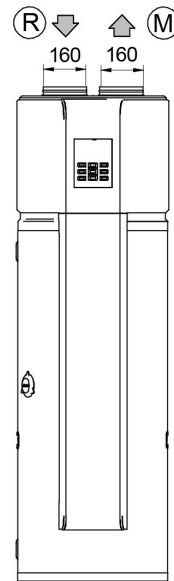

Unit attacks 300

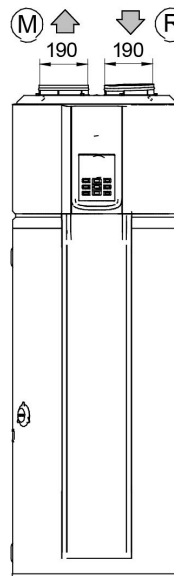

R - External air return

M - Air supply



Avoid recirculation of exhaust/return air

- Use elbows with a 90° downward bend (1,2)
- Minimum distance 800mm (3,4)
- External air return
- positioned in an area with a low concentration of impurities (dust, odours, exhaust fumes, etc.).

Exhaust outlet

- away from terraces, balconies, property boundary lines;
- avoid windward zones

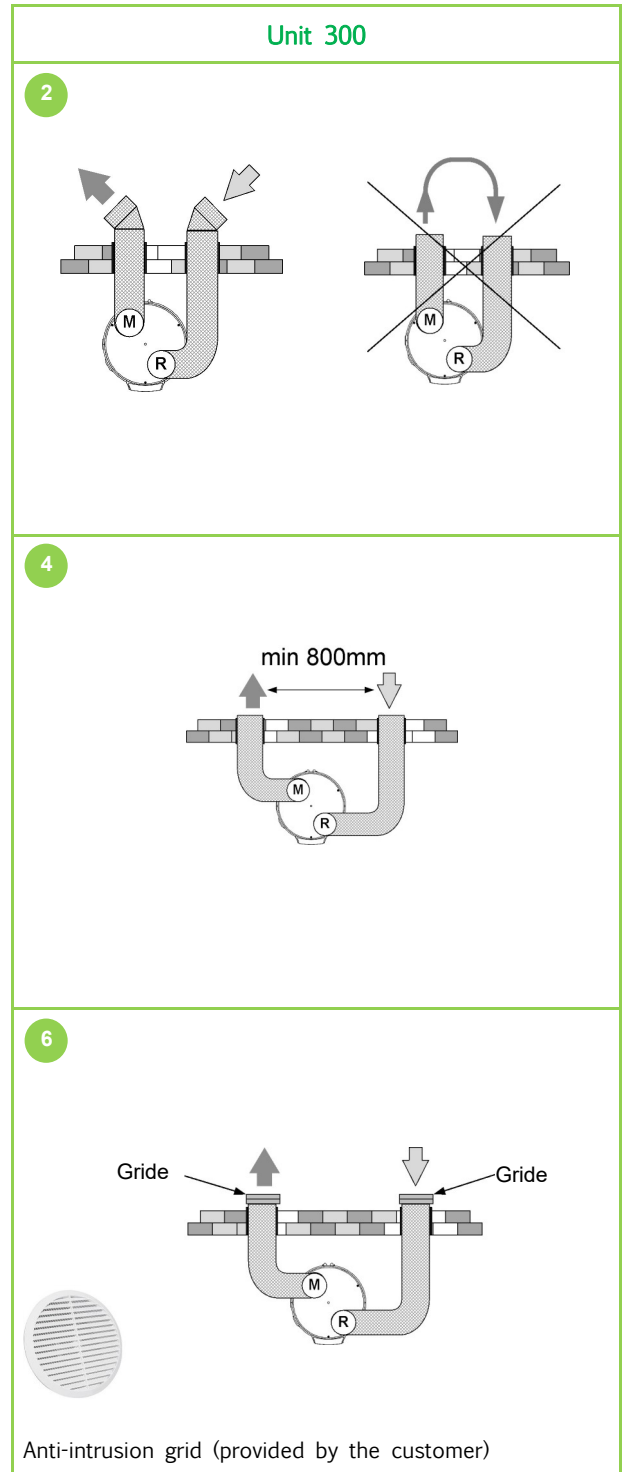
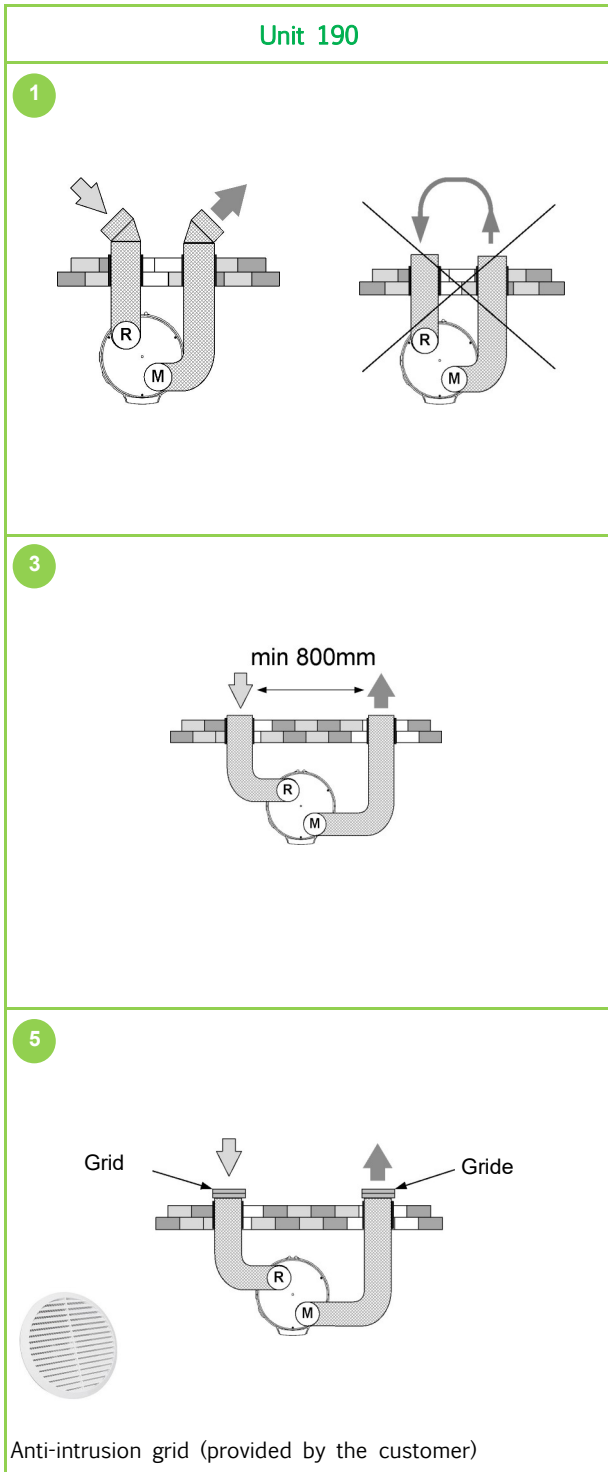

7 AERAILIC CONNECTIONS



In terms of the unit connect with duct reaching to outdoor, a reliable water-resistant measure must be conducted on the duct, to prevent water from dropping into internal of the unit .
In case the water entering to internal components of the unit, the component might be damaged or causing physical danger.

The ducts should not be tilted towards unit to avoid the condensate and water return.

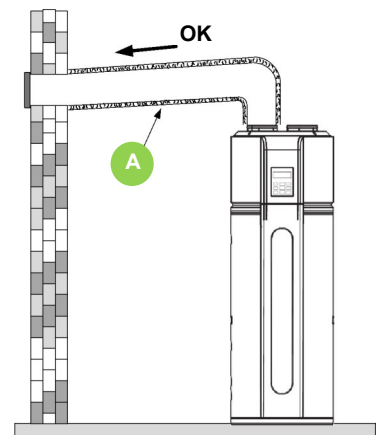
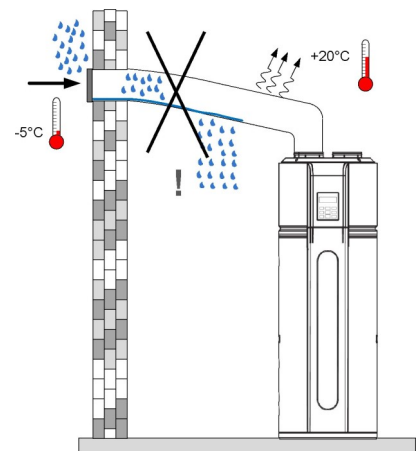
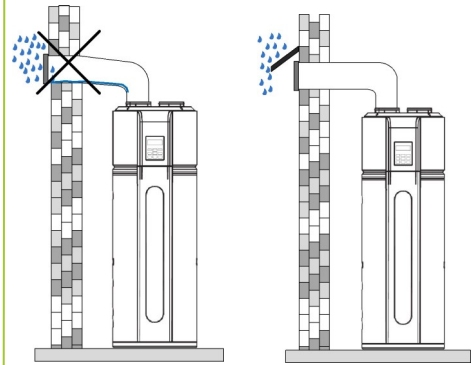

A - Insulated pipe



Grid to prevent small animals or leaves from entering inside (provided by the customer)

Installing at the unit inlet.

In terms of the unit with duct, grid there must be put on the position of duct inlet. (Provided by the customer)

The grid must be provided on the intake outlet of the external air or on the duct easily accessible for routine maintenance (Provided by the customer), the mesh size is about 1.

Grid position (A)

- intake outlet (1,4)
- on duct (2,3)

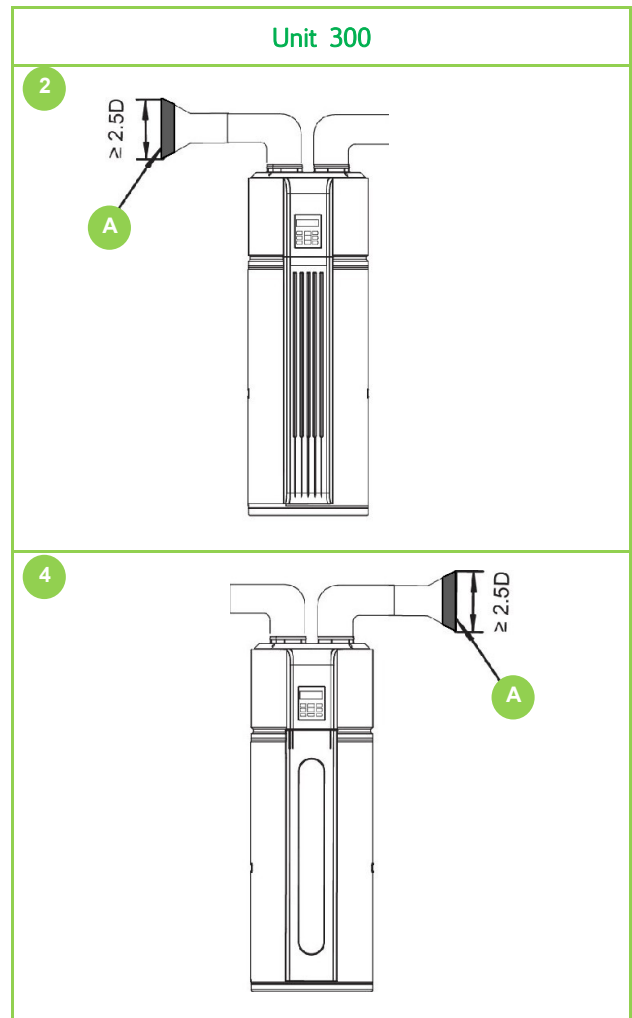
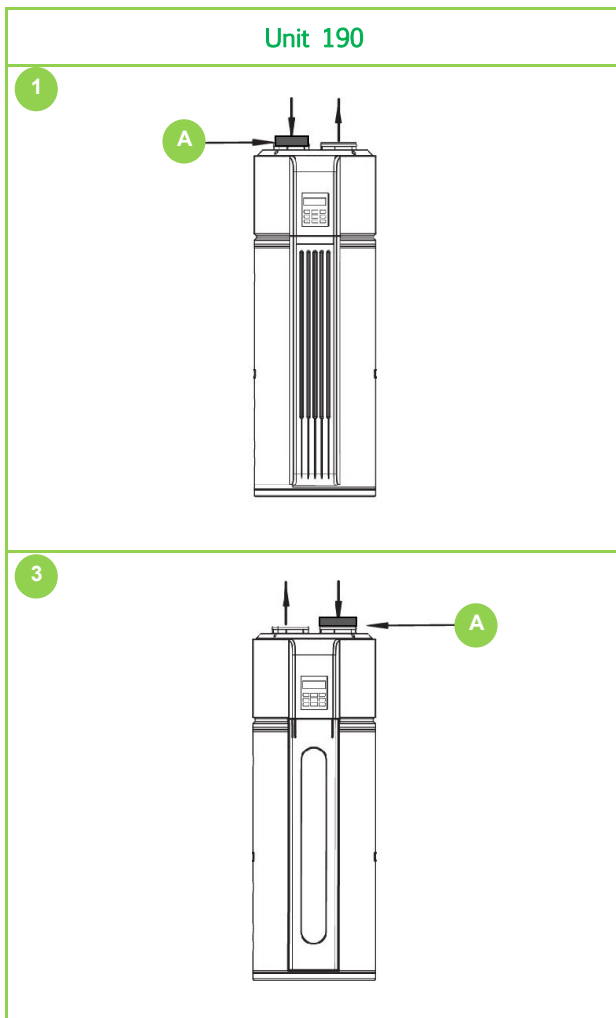



Electrical wiring diagram - Unit 190

A - Wire comes out from tank, must connect with the corresponding component.

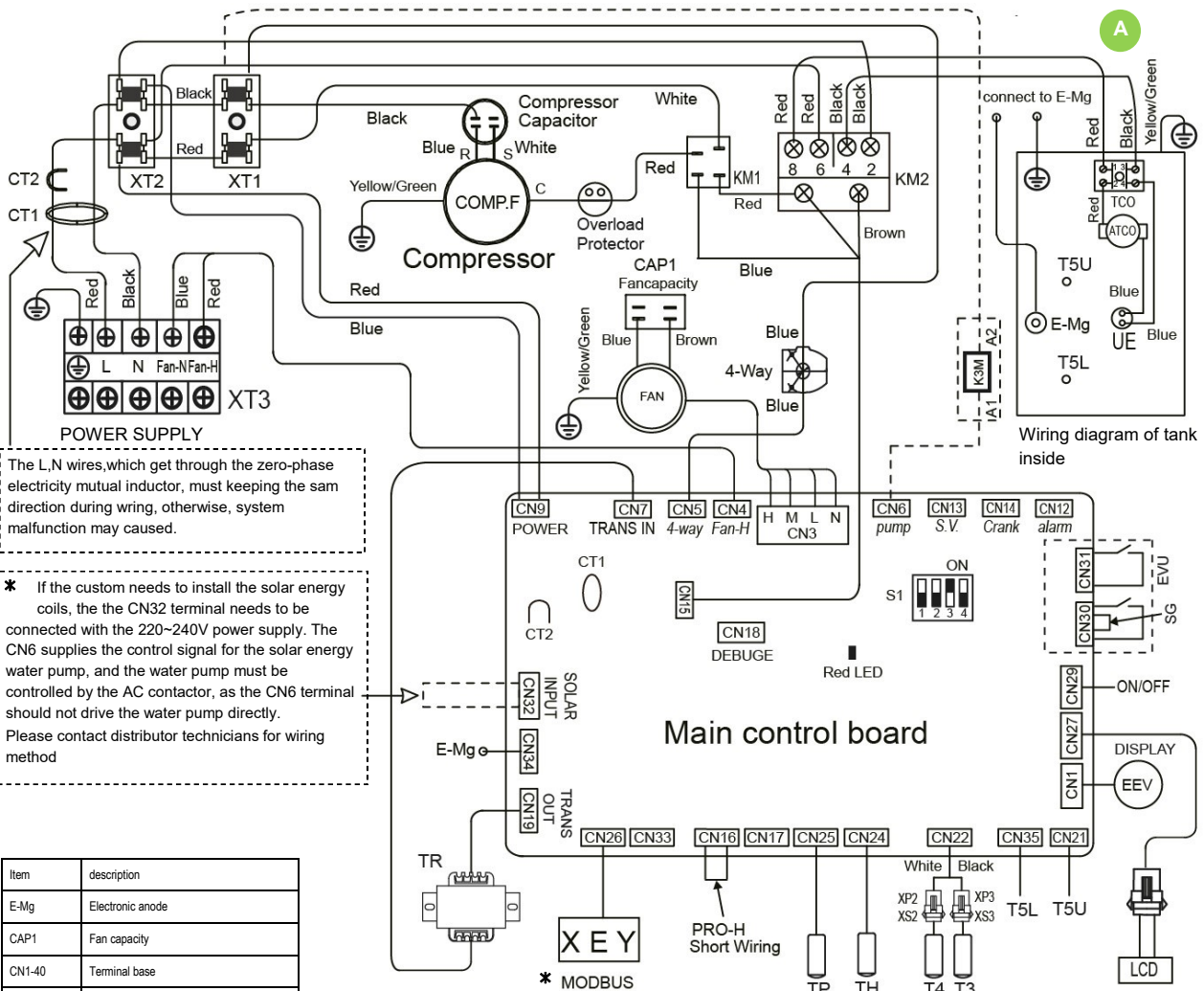

Item	description
E-Mg	Electronic anode
CAP1	Fan capacity
CN1-40	Terminal base
TR	Transformer
CT1	Zero-phase electricity mutual inductor
CT2	AC mutual inductor
XP1-3	Connector
XS1-3	Connector
RY1,3	Relay connecting wires
KM1,KM2	Relay
MODBUS	Supervisor connection
UE	Electric heater of the tank
ATCO	Automatic temperature recover switch
XT1,XT2,XT3	Mid terminal base
EVV	Electric expansive valve
K3M	AC contactor

T3	Evaporator temperature sensor
T4	Ambient temperature sensor
T5U	Tank temperature sensor (Upper)
T5L	Tank temperature sensor (Lower)
TP	Discharge temperature sensor
TH	Suction temperature sensor

T3: Evaporator temperature sensor
 T4: External temperature sensor
 T5U: Storage tank temperature sensor (Upper)

T5L: Storage tank temperature sensor (Lower)
 TP: Discharge temperature sensor
 TH: Suction temperature sensor

* For the connection see last pages



Electrical wiring diagram - Unit 300

A - Wire comes out from tank, must connect with the corresponding component.

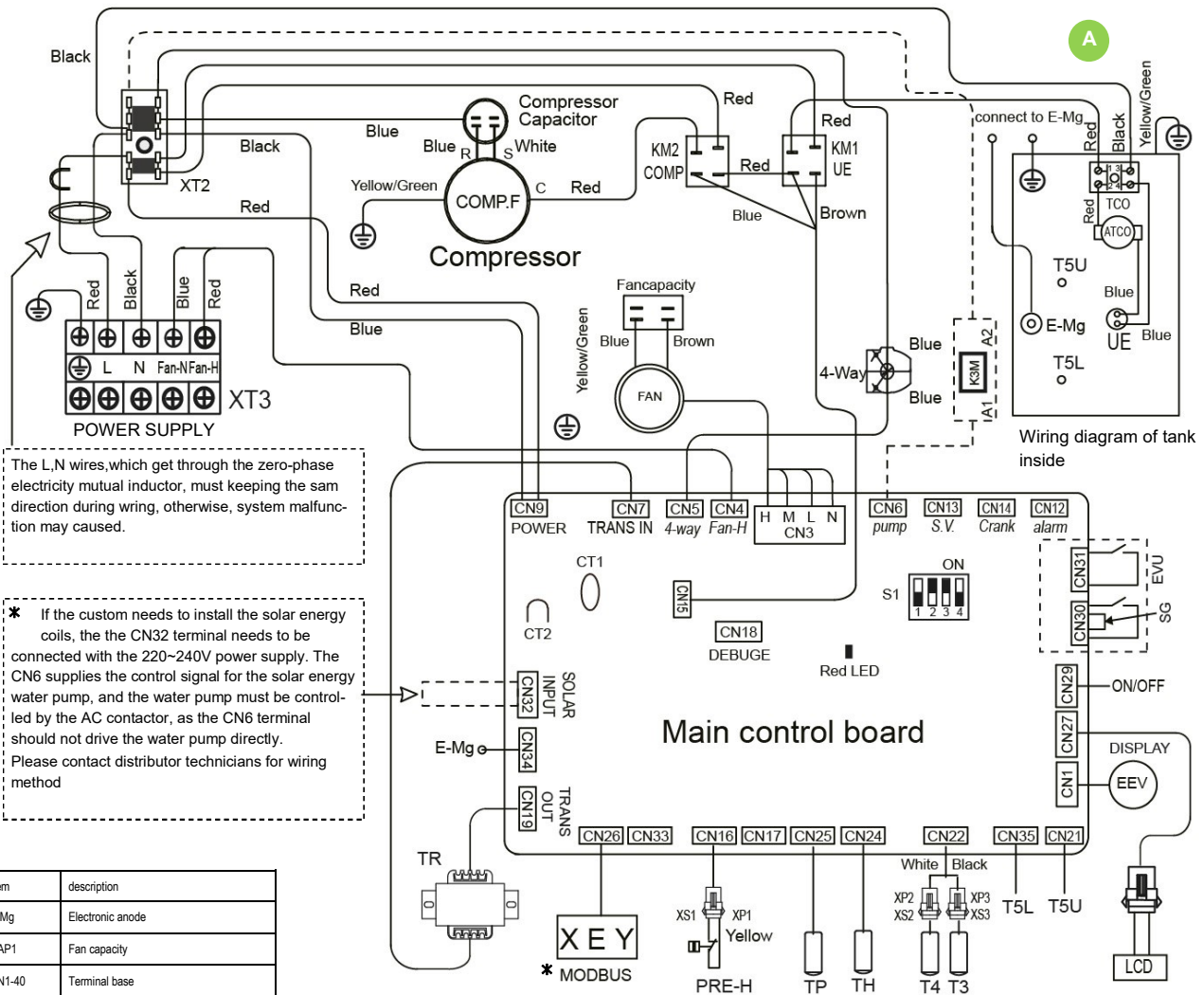

The L, N wires, which get through the zero-phase electricity mutual inductor, must keep the same direction during wiring, otherwise, system malfunction may be caused.

* If the custom needs to install the solar energy coils, the CN32 terminal needs to be connected with the 220~240V power supply. The CN6 supplies the control signal for the solar energy water pump, and the water pump must be controlled by the AC contactor, as the CN6 terminal should not drive the water pump directly. Please contact distributor technicians for wiring method

Item	description
E-Mg	Electronic anode
CAP1	Fan capacity
CN1-40	Terminal base
TR	Transformer
CT1	Zero-phase electricity mutual inductor
CT2	AC mutual inductor
XP1-3	Connector
XS1-3	Connector
RY1,3	Relay connecting wires
KM1,KM2	Relay
MODBUS	Supervisor connection
UE	Electric heater of the tank
ATCO	Automatic temperature recover switch
XT1,XT2,XT3	Mid terminal base
EVV	Electric expansive valve
K3M	AC contactor

T3	Evaporator temperature sensor
T4	Ambient temperature sensor
T5U	Tank temperature sensor (Upper)
T5L	Tank temperature sensor (Lower)
TP	Discharge temperature sensor
TH	Suction temperature sensor

T3: Evaporator temperature sensor
 T4: External temperature sensor
 T5U: Storage tank temperature sensor (Upper)
 TP: Discharge temperature sensor
 TH: Suction temperature sensor

T5L: Storage tank temperature sensor (Lower)
 TP: Discharge temperature sensor
 TH: Suction temperature sensor

* For the connection see last pages

8 ELECTRICAL CONNECTIONS



All electrical operations should be performed by trained personnel having the necessary requirements by the regulations in force and being informed about the risks relevant to these activities.

Min. Diameter of Power Supply Cord (mm ²)	4
Earth Cord (mm ²)	4



Please choose the power cord according to above table, and it should comply with local electric standard.

The power cord type, recommended power cord mode is H05RN-F.

When wiring the power supply, please add additional insulation sheath at the place without rubber insulation layer.

- ⇒ *The unit must be installed with an Creepage Breaker near the power supply and must be effectively earthed.*
- ⇒ *A creepage breaker must be installed adjacent to the power supply*
- ⇒ *Never use the wire and fuse with wrong rated current, otherwise unit may break down and cause fire furthermore.*



Electric Connection

The power supply should be an independent circuit with rated voltage.

Power supply circuit should be earthed effectively.

Do not use water pipes to earthing connection of the unit

The wiring must be performed by professional technicians in accordance with national wiring regulations and this circuit diagram.

An all-pole disconnection device which has at least 3 mm separation distance in all pole and a residual current device (RCD) with the rating of above 10 mA shall be incorporated in the fixed wiring.

Set the electric leakage protector according to the relevant electric technical standards of the State.

The power cord and the signal cord shall be laid out neatly and properly without mutual interference or contacting the connection pipe or valve.

After wire connection, check it again and make sure the correctness before power on.

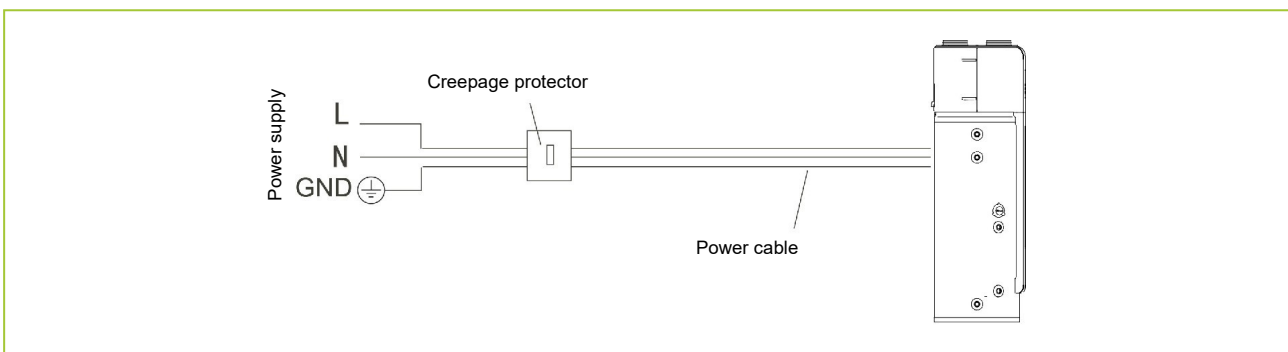

CAUTION

The earthing pole of socket must be grounded well, make sure that power supply socket and plug are dry enough and connected tightly.

SMART GRID management - Photovoltaic

	EVU Photovoltaic signal	SG Smart grid
Unit works normally	OFF	ON
Unit is turned off.	OFF	OFF
Forced unit in operation with electrical resistance, even if it was off, with temperature increased to 70 °C	ON	ON or OFF

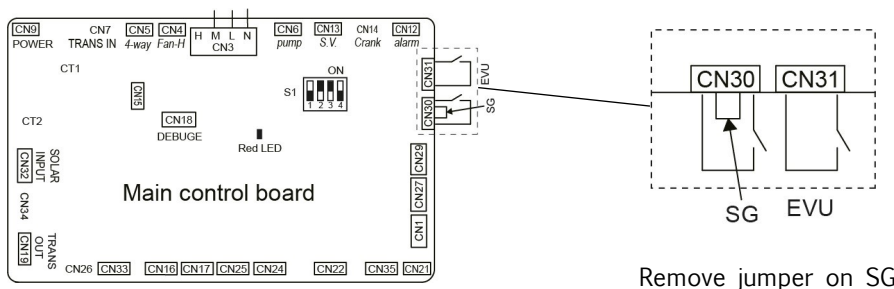



Note

⇒ *If the unit has been tipped during transport, wait at least 2 hours before starting it up*

General

The indicated operations should be done by qualified technician with specific training on the product.

Upon request, the service centres performing the start-up.

The electrical, water connections and the other system works are by the installer.

Agree upon in advance the star-up data with the service centre.

Before checking, please verify the following:

- the unit should be installed properly and in conformity with this manual
- the electrical power supply line should be isolated at the beginning
- the unit isolator is open, locked and equipped with the suitable warning
- make sure no tension is present

Warning

⇒ *After turning off the power, wait at least 5 minutes before accessing to the electrical panel or any other electrical component.*

⇒ *Before accessing check with a multimeter that there are no residual stresses.*

Note

⇒ *Before starting the unit, make sure that the room is free of dust and debris and that the conduits are not blocked*

The following check list is a brief reminder of the points to check and of the operations to perform to start-up the unit.

For details refer to the various chapters in the manual.



Preliminary checks		Yes / No
1	The flooring must be able to support the weight of the unit when full with water (see dimensional)	
2	Unit installed inside, in a vertical position and sheltered from freezing temperatures.	
3	The site location must be free from any corrosive elements in the atmosphere such as sulfur, fluorine, and chlorine and dust in excessive quantities.	
4	Sufficient air flow for the unit to function. The unit must be located in a space $>15\text{m}^3$, and must have unrestricted air flow. The unit cannot be placed into any type of closet or small enclosure.	
5	Sufficient room to maintenance the unit.	
6	All piping properly installed and free of leaks.	
7	Filter for water coming from water mains present and accessible for maintenance	
8	Condensate drain pipe connected and conveyed to an adequate drain, protected from frost	
9	DHW safety valve pipe connected and conveyed to an adequate drain, protected from frost	
10	Water temperature limit valve or mixer tap (recommended) installed per manufacturer's instructions.	
11	Hydraulic system filled, pressurised and drained	
12	Sufficient inlet water pressure, between 1,5 Bar ~ 6,5 Bar (0,15 MPa ~ 0,65 MPa) ($\geq 1,5\text{Bar}$) ($\geq 0,15\text{MPa}$)	
13	Expansion tank checked / filled with nitrogen	
14	The unit and electrical system are properly grounded.	
15	Present overload protection / differential switch.	
16	Power supply and connections cables comply with national standards and the requirements of this manual.	
17	Power supply voltage within the limits: 220-240Vac	
18	The external air temperature within the limits: above -7°C and below 43°C If the external air temperature falls outside these upper and lower limits the electrical elements will be activated to meet the hot water demand	
19	Is the pressure relief valve present? Is the setting correct?	
20	Joints Diélectriques présents ?	



Post Installation Review		Yes / No
1	Understand how to use the User Interface Module to set the various modes and functions.	
2	Periodically check of the condensate drain pan and lines.	
3	IMPORTANT: Water coming from the plastic shroud is an indicator that both condensation drain lines may be blocked. Immediate action is required.	
4	To maintain optimal operation check, remove and clean the air filter.	

Site location

The site location must be free from any corrosive elements in the atmosphere such as sulfur, fluorine, and chlorine.

These elements are found in aerosol sprays, detergents, bleaches, cleaning solvents, air fresheners, paint, and varnish removers, refrigerants, and many other commercial and household products. An excessive dust and lint may affect the operation of the unit and require more frequent cleaning.

Refrigerant circuit

Visually check the refrigerating circuit: the presence of oil stains can mean leakage (caused, for example, by transport, handling or other).

Use the pressure taps only if you need to load or unload the refrigerant circuit.

Hydraulic circuit

Before realizing the unit connection make sure that the hydraulic system has been cleaned up and the clearing water has been drained .

Check that the water circuit has been charged and pressurised .

Check that the cut-off valves on the circuit are in the "OPEN" position.

Check that no air is present in the circuit, if required, evacuate using the air bleeding valve placed at the system's high points.

Aeraulic system

Verify that:

- the rooms are clean (free from dirt)
- ducting are completed, connected and without obstructions

Electrical circuit

Verify that the unit is connected to the ground plant .

Check tightening of the conductors: the vibrations caused by handling and transport might cause loosing .

Feed the unit by closing the sectioning device, but leave it on OFF
220/240V +/- 10%

50 Hz +/- 1%

The operating out of the limits can cause malfunctions damages and makes decay the warranty.



Verify tensions - Absorptions

Check that the air and water temperatures are within the operating limits.

With unit at steady state, i.e. in stable and close-to-work conditions, check:

- supply voltage
- unit total absorption
- absorption of each electric load..

Power supply socket

For verify power supply socket:

- turn on power supply and keep the unit running for a half hour;
- turn off power supply and plug out, check whether the socket and plug is hot or not.

Trial-running

Water effusion before operation

Note

⇒ *Before using this unit, please follow the steps below.*

Storage tank water filling:

- If the unit is used for the first time or used again after emptying the storage tank, please make sure that the storage tank is full of water before turning on the power
- Open the cool water inlet valve and the hot water outlet valve.
- When water flows out from the water outlet (DHW), the storage tank is full.
- Turn off the hot water outlet valve and water effusion is finished.

Note

⇒ *Operation without water in water storage tank may result in the damage of auxiliary e-heater. Due to such damage, manufacturer will not be liable for any damages caused by this issue*





About Running

- 1 System Structure Figure
Unit has two kinds of heat sources: Heat pump(compressor) and electric heater.
Unit will automatically select heat sources to heat water to the target temperature.
- 2 Water Temperature Display
The temperature shown on the display depends on the upper sensor. So it is normal that the display temperature has reached to target temperature but compressor still running, because the lower water temperature does not get to target temperature.
Modes will be automatically selected by unit. manually mode selection is unavailable.
- 3 Heat source will be automatically selected by unit. But manually E-Heater operation is available.
- 4 Heat Source Shift
The default heating source is heat pump.If externalis range out of heat pump, heat pump will stop running, the unit will shift automatically to activate E-heater and show the icon LA on the display, then if the externaltemperature goes into the running range of heat pump again, it will stop E-heater and shift automatically to heat pump again, and the icon LA will be extinguished.
If the target setting water temperature is higher than Max. temp (Heat pump), the unit will activate heat pump firstly to the Max. temperature, then stop heat pump, activate E-heater to continually heat water to the target temperature.
If manually activate the E-heater running mode when heat pump running, E-heater and heat pump will work together until the water temperature gets to target temperature.
So if want to heat quickly, please manually activate E-heater.

Note

⇒ E-heater will be activated once for the current heating progress, if want to apply E-heater again please push E-HEATER.

If system occurs some malfunctions, error code "E7" and  , e will be shown on the display, then heat pump will stop running, and the unit will activate automatically E-heater as the backup heat source, but the code "E7" and  will be shown until power off.

If only use E-heater, about only 75 liters water (unit 190) will be heated or about only 150 liters water (unit 300), so must set higher target water temperature if externaltemperature is out of heat pump running range.

Defrosting During Water-heating

In heat pump running period, if the evaporator frosted in lower ambient temperature, the system will defrost automatically to keep effective performance(about 3~10min). At defrosting time, the fan motor will stop, but compressor will still run.

TCO and ATCO

The power of compressor and E-heater will be automatically shut-off or turn on by TCO and ATCO.

If the water temperature is higher than 78°C, the ATCO will automatically shut off the power of compressor and E-heater, and reconnect it if the temperature falls down below 68°C.

the water temperature is higher than 85°C, the TCO will automatically shut off the power of compressor and E-heater.

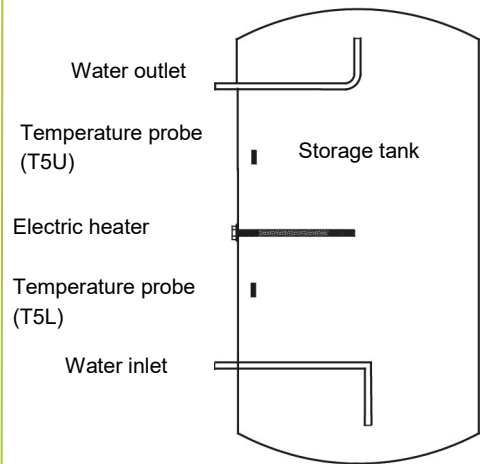







After that it needs to be reset manually by pressing the red button on the TCO.

Note

⇒ While the external temperature below than -7°C , heat pump efficiency will decrease dramatically, the unit will automatically shift to E-heater mode.

Basic function

How is the unit running

If unit is OFF, press  unit will be waken, press   to set target water temperature ($38\text{-}70^{\circ}\text{C}$), press  unit will automatically select mode and start to heat water to target temperature.

Vacation mode

After pressing "Vaction" button, unit will automatically heat water to 15°C for the purpose of energy saving during vacation days.

Weekly disinfect function

Under disinfection mode unit immediately start to heat water up to 70°C to kill the potential legionella bacteria inside water of storage tank,  icon will light on the display screen during disinfection.

Unit will quit disinfection mode if water temperature is higher than 70°C .

Starting report

Reading the objective operating conditions is useful for checking the unit over time.

With unit of full load, namely in stable conditions and close to those of work, take the following data:

- Voltage and general absorptions with unit at full load
- Absorption of varied electrical loads (compressors, fans, etc)
- Temperature and air flow, both inlet and outlet from unit, fridge data
- The readings should be stored and made available during maintenance .





Keyboard

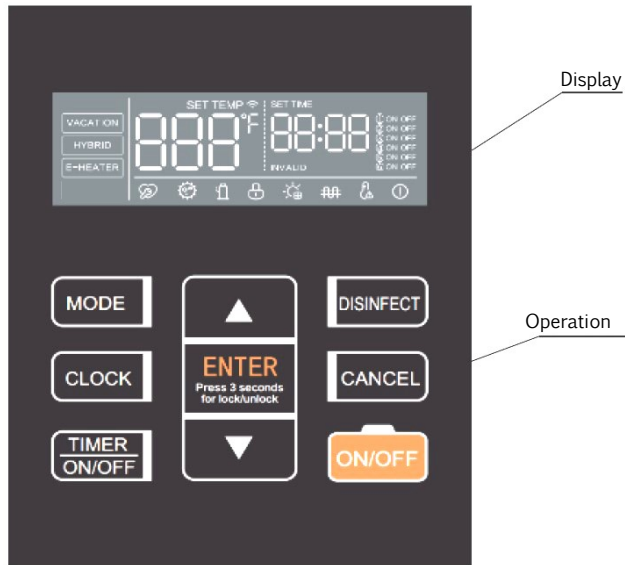

Icons

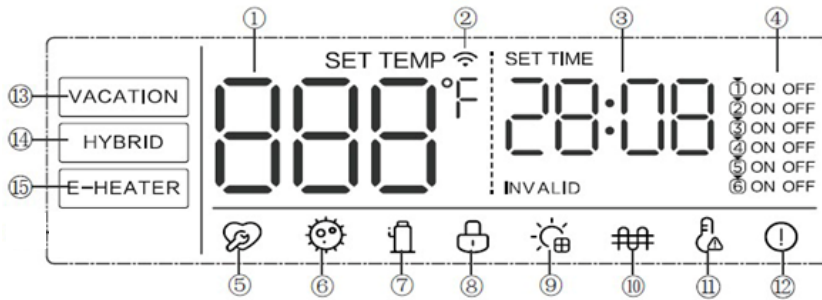

No.	Icon	Description
①		On: screen locked. It can display: <ul style="list-style-type: none"> the normal water temperature; the remaining days in vacation mode; the temperature set when setting the parameters; the unit's setting/operation parameters; the error code/protection in diagnostics mode.
②		On: WiFi connected; Off: WiFi not connected; Flashing: WiFi setting up.
③		Indicates the time. SET TIME: on if setting the time.



④		<p>6 programs can be set Corresponding icon on: program set. Corresponding icon off: program not set. When the program is set, the corresponding icon flashes at a frequency of 2Hz and the set program will light up.</p>
⑤		Reserved
⑥		Unit in disinfection cycle. (antilegionella)
⑦		Compressor in operation.
⑧		Buttons locked.
⑨		Unit connected to the solar signal or to the solar water pump.
⑩		Electric heater in operation
⑪		High temperature alarm Water temperature above 50°C
⑫		Unit in error/protection.
⑬		Unit works in VACATION mode. There are 14 default vacation days; they can be set in a range from 1 to 360. Disinfect mode is automatically activated on the last day of the holiday. At the end of the cycle, the temperature value set before vacation mode was activated is restored.
⑭		Unit in HYBRID mode.
⑮		Unit in E-HEATER mode.
⑯	INVALID	An invalid button was pressed.
⑰	SET TEMP	On: water temperature setting.
⑱	SET TIME	On: time setting.





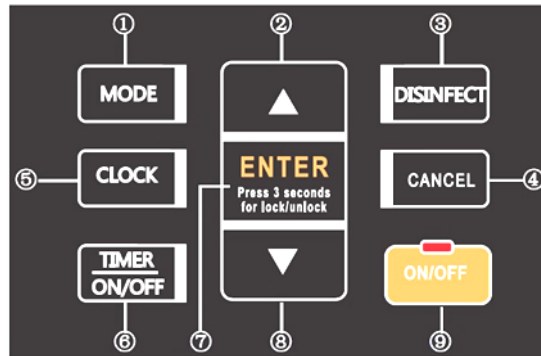



Each button press is only effective when the display is unlocked.



No.	Icon	Description
①		<p>Use the button to change mode</p> <p>Default HYBRID mode</p> <p> Switches to E-heat mode</p> <p> Switches to VACATION mode</p> <p> Sets the vacation days (1-360 days)</p> <p> Switches to HYBRID mode</p>
②		<p>+ / UP</p> <p>Increases the corresponding value.</p> <p>Pressed for more than 1s: the value increases continuously.</p>



<p>③</p> <p>DISINFECT</p>	<p>DISINFECT DISINFECT</p> <p>Manually turns the disinfection function on</p> <p>DISINFECT The  icon flashes, then the unit heats the water to at least 70°C for disinfection.</p> <p>↓</p> <p>DISINFECT When the unit is being disinfected, press this button to cancel the operation.</p> <p>The  icon turns off.</p> <p>DISINFECT WiFi on/off</p> <p>↓</p> <p>Press the DISINFECT button for 3 sec to turn the WiFi on.</p> <p>CANCEL The button is used to cancel all the settings and exit the settings status. When the WiFi connection is normal, press and hold the Cancel button for more than 8 s to exit the WiFi connection.</p>
<p>⑤</p> <p>CLOCK</p>	<p>CLOCK Press the button to enter the time setting. SET TIME will light up and the hour value will flash</p> <p>↓</p> <p>  Set the hour value</p> <p>↓</p> <p>ENTER Confirm the hour value and enter the minutes value <small>Press 3 seconds for lock/unlock</small></p> <p>↓</p> <p>  Set the minutes value</p> <p>↓</p> <p>ENTER Confirm the time setting <small>Press 3 seconds for lock/unlock</small></p>



Timer button



Enter the 6-segment programming setting; the ON icon is always on. Enter the TIMER ON setting; the hour value will flash



Set the hour value



Confirm the hour value and enter the minutes value



Set the minutes value



Confirm the minutes value and enter the TIMER OFF setting. The 1OFF icon is now always on and the hour value will flash



Set the hour value



Confirm the hour and enter the minutes



Set the minutes value



Confirm the minutes value and finish setting the first programming segment







6



NOTE

- 1 During the setting process, press the TIMER ON/OFF button to enter the next ON/OFF setting
- 2 During the setting process, press the TIMER ON/OFF button to enter the next part of this segment
- 3 During the setting process, press the Cancel button to cancel the current programming operation and return to the main interface
- 4 If there are any conflicts in the time set, the last time set will apply; any previous setting will automatically be cancelled. If the TIMER ON/OFF value set is the same, the setting of this segment will not be valid



7		<p>CONFIRM / UNLOCK</p> <p>If the screen and buttons are unlocked, press this button to load the setting parameters after setting a parameter:</p> <ul style="list-style-type: none"> • If it is pressed within 10 sec, the setting parameters will be loaded into the unit; • If it is pressed after 10 sec, it resets all the parameters. <p>If the screen and buttons are locked, press and hold this button for 3 s to unlock them.</p>
8		<p>- / DOWN</p> <p>Decreases the corresponding value. Pressed for more than 1s: the value decreases continuously</p>
9	 	<p>ON/OFF button and LED indicator</p> <p>Unità in standby: press  , the unit turns off.</p> <p>Unità on: press  , the unit turns off.</p> <p>Unit off: press  , the unit turns on.</p> <p>LED: on: unit on; off: unit off.</p>

Anti-legionella

 Choose 01	<p>Press the confirmation button.</p> <p>the DISINFECT icon and the first two values of 8888 flash the hour can be changed.</p> <p>Press the confirmation button,</p> <p>the last two values of 8888 flash the minutes can be changed.</p> <p>After setting, press OK to save the settings and exit.</p> <p>Press the Cancel button to exit the disinfection time setting.</p> <p>If no disinfection start time has been set, disinfect once every 7 days using 23:00 as the default setting.</p> <p>If the disinfection start time has been set, disinfection will be carried out once every 7 days according to the disinfection start time set.</p>
--	--

Changing the unit of measurement °F / °C

 Choose 02	<p>Press the confirmation button.</p> <p>the LCD displays F or C; press   to switch from °F to °C and vice versa</p>
--	--

Alarms reset

 Choose 03	<p>Press the confirmation button.</p> <p>the alarm beeps briefly</p> <p>the error code / protection is reset</p>
--	--

10 CONTROL



Query function

For the convenience of maintenance and debug, query function is available by press buttons together **MODE** + **CLOCK** + **▲**, then system running parameters will be shown one by one with following sequence by each pushing of **▲** or **▼**.

Hour bit high	Minutes bit high	Minutes bit high	Temp.		Description
t	S	U	Temp	°C	T5U: Storage tank temperature sensor (Upper)
t	S	L	Temp	°C	T5L: Storage tank temperature sensor (Lower)
	t	1	Temp	°C	Reserved (display --)
	t	7	Temp	°C	Reserved (display --)
	t	3	Temp	°C	T3: Evaporator temperature sensor
	t	4	Temp	°C	T4: Ambient temperature sensor
	t	P	Temp	°C	Tp: Compressor discharge temperature sensor
	t	H	Temp	°C	Th compressor suction temperature sensor (display --)
	t	t			Clock chip: normal view --, EF abnormal view
	U	o	Current		Current value
	U	E	Current		Current electric heating value (display --)
	F	0	Fan speed		0 stopped, 1 low speed, 2 high speed
E	E	A	Opening degree		Electronic expansion valve (displays --)
E	E	b	Opening degree		Reserved (display --)
E	E	U	Frequency		Compressor frequency (display --)
	U	1	Version		Software version
	U	2	Version		HMI software version
1	X	X	Code		Last error code
2	X	X	Code		Penultimate error code
3	X	X	Code		Third to last error code
E	n	d	--		End



Using the unit with the MSmartLife App

Before starting, make sure:

1. Your smartphone is connected to your home WiFi network and you know the network password.
2. You are close to the appliances.
3. The 5GHz or 2.4GHz (preferable) wireless signal is enabled on your wireless router.

1 Download the MSmartLife App

Scan the QR code or search for “MSmartLife” in Google play (Android devices) or App Store (iOS devices) to download the app.

2 Register or log in to your account

Open the App and create a user account or log in to your account.

3 Add the device

Press the “+” icon to add an appliance to your MsmartLife account.

4 When connected to the network

Follow the instructions in the app to connect to the WiFi. If the network connection does not work, refer to the tips on how to operate the App.





Auto-restart

If electricity power failed, unit can memorize all setting parameters, unit will be back to the previous setting when power recover.

Button Auto Lock

When there is no operation of button for 1 minute, button will be

locked except Unlock button ()

Press  for 3 sec., unlock buttons..

Screen Auto Lock



If there is no operation of button for 30sec., screen will be locked (extinguished) except for error code and alarm light.

Press any button will unlock the screen (lighten)

Something about self-protection of unit

When the self-protection happens, the system will be stopped and start self-check, and restart when the protection resolved.

When the self-protection happens, the  will flash and error code will be shown at water temperature indicator.

Press  button for 1sec to stop the will flash, but the  and error code does not disappear until protection resolved.

In the following circumstance, self-protection may happen:

- Air inlet or outlet is blocked;
- The evaporator is covered with too much dust;
- Incorrect power supply (exceeding the range of 220-240V $\pm 10\%$).

Contact service center.

When Error happened

If some normal errors happen, unit will automatically shift to E-Eheater for emergent DHW supply.

Please contact qualified staff to repair.

If some sever error happen, unit will not start, please contact qualified staff to repair.

If some errors happen, the  will flash fast.

Press  for 1 sec to stop the will flash, but the alarm icon will keep glittering.



Risoluzioni problemi

Error	Possible reason	Solution
Cold water tapped out and display screen extinguished	Bad connection between power supply plug and socket; Setting water temperature too low; Temper sensor broken ; PCB of indicator broken.	Connect again the supply plug Setting water temp. higher; Contact service center.
No hot water tapped out	Public water supply ceased; Cold water inlet pressure too low (<0,15 Bar) (<0,015 MPa); Cold water inlet valve closed.	Waiting for public water supply recover; Waiting for inlet water pressure increase; Open water inlet valve.
Water leakage	Hydraulic pipeline joints are not sealed well.	Check and reseal all joints.



Allarms

Code	Description	Solution
E0	Error of sensor T5U (upper water temperature sensor)	Maybe the connection between sensor and PCB has released or sensor has been broken. Contact a qualified person to service the unit.
E1	Error of sensor T5L(lower water temperature sensor)	Maybe the connection between sensor and PCB has released or sensor has been broken. Contact a qualified person to service the unit.
E2	Storage tank and Wired Controller communication error	Maybe the connection between controller and PCB has released or PCB has been broken.
E4	Evaporator temperature sensor T3 error	Maybe the connection between sensor and PCB has released or sensor has been broken. Contact a qualified person to service the unit.
E5	Ambient temperature sensor T4 error	Maybe the connection between sensor and PCB has released or sensor has been broken. Contact a qualified person to service the unit.
E6	Compressor discharge temperature sensor TP error	Maybe the connection between sensor and PCB has released or sensor has been broken. Contact a qualified person to service the unit.
E8	Electric leakage error If PCB current_induction_circuit check the current difference between L,N >14mA, system consider it as "electric leakage error"	Maybe some wires have been broken or bad wire connection. Contact a qualified person to service the unit.
E9	Compressor suction temperature sensor TH error	Maybe the connection between sensor and PCB has released or sensor has been broken. Contact a qualified person to service the unit.
EE	E-heater open-circuit error IEH (Current difference E-heater on and off)<1A	Maybe the E-heater has been broken or bad wire connection after repair. Contact a qualified person to service the unit.
EF	Clock chip error	Maybe the chip has been broken, but unit can work well without clock-memory, so it is needed to reset clock when power put on again. If necessary, contact a qualified person to service the unit.
Ed	E-EPROM chip error	Contact a qualified person to service the unit.



Allarms

Code	Description	Solution
P1	System high pressure protection: Unit 300 : >=3.0Mpa active; <=2.4MPa inactive. Unit 190 : P1 error code never appear because pressure switch	Maybe because of system blocked, air or water or more refrigerant in system (after repair), water temperature sensor malfunction, ect. Contact a qualified person to service the unit.
P2	High discharge temperature protection Unit 190/300 : >115 °C Protection active; <90 °C Protection inactive	Maybe because of system blocked, air or water or less refrigerant(leakage) in system(after repair), water temperature sensor malfunction, ect. Contact a qualified person to service the unit.
P3	Compressor abnormally stopped protection The discharge temperature is not so higher than evaporator temperature after compressor running a term.	Maybe because of compressor broken or bad connection between PCB and compressor.
P4	Compressor overloaded protection (10 sec after compressor startup, Current checking starts , 1) only compressor running, if it is >10A , the compressor will be stopped and protected.) 2) Compressor + e-heater opened, if it is >IEH+10,the compressor will be stopped and protected.) Possible absorption or abnormal activation of the electrical resistance.	Maybe because of compressor broken, system blocked, air or water or more refrigerant in system(after repair), water temperature sensor malfunction, ect. Check that the resistance does not absorb current when the display is turned off. This circumstance is interpreted by the unit as a compressor anomalous absorption. Contact a qualified person to service the unit.
LA	When the ambient temp T4 is out of Heat Pump running range (-7 ~ 43 °C) Heat Pump will stop, unit will show LA on the position of clock on display until T4 back to (-7 ~ 43 °C). Only valid for the unit without e-heater. Unit with e-heater will never show "LA".	It is normal, and no necessary to repair.

Note

⇒ The alarm codes listed above are the most common. If a alarm code not listed above is displayed, contact technical assistance.

⇒ If any of P3/P4/P2/P1 continuously appear 3 times within single heating cycle, system will consider it as "Heat Pump system error".

Contact a qualified person to service the unit.



Frequent questions

Q: Why compressor can't start immediately after setting?

A: Unit will wait for 3 min to balance the pressure of system before start compressor again, it's a self protection logic of unit.

Q: Why sometimes the temperature shown on the display panel decreased while unit is running?

A: R. When hot water is sampled, it is mixed with cold water which is added from the low part of the accumulator.

Q: Why sometimes the temperature shown on the display decreased but unit still keep closed?

A: To avoid unit ON/OFF frequently, unit will activate heat source only when bottom storage tank temperature is lower than setting temperature for at least 6°C.

Q: Why sometimes the temperature shown on the display will decreased dramatically?

A: Because storage tank is pressure-bearable type, if there is massive hot demand, hot water will quickly tapped out from upper part of storage tank as well as cold water will quickly tapped into bottom part of tank, if the cold water surface emerge the upper temperature sensor, temperature shown on the display will decreased dramatically.

Q: Why sometimes the temperature shown on the display is decreased a lot, but there is still a mount of hot water can be tapped?

A: Because the upper water sensor is located on the upper 1/4 storage tank, when tapping hot water out, it means there is at least 1/4 storage tank of hot water available.

Q: Why sometimes unit shows "LA" on display ?

A: The heat pump available running externalrange is -7 ~ 43°C, if externaltemperature is out of range, system will show abovementioned signal to let user notice it.

Q: Why something there is nothing shown on the display?

A: To maintain display screen lifespan within along term, when there is no button operation for 30 sec, it will extinguish the display except the LED indicator.

Q: Why sometimes the buttons are unavailable?

A: If there is no operation on panel for 1 min, unit will lock the panel, shows "  ", to unlock the panel, please press the "Enter" button for 3 seconds.

Q: Why sometimes there is some water flowed from drainage pipe of saftey valve?

A: Because the storage tank is pressure-bearable one, when water is heated inside the storage tank, water will expand, so the pressure inside of tank will increase, if pressure goes up more than 7Bar (0,7Mpa), saftey valve will activate to relief the pressure and hot water drop will be discharged correspondingly. If water drop is continually discharged from saftey valve drainage pipe, it is abnormal, please contact qualified stuff to repair.



Safety

Operate in compliance with safety regulations in force .
Use single protection devices: gloves, glasses, helmet etc.

General

Maintenance must be performed by authorized centres or by qualified personnel

The maintenance allows to:

- maintaining the unit efficient
- reduce the deterioration speed all the equipment is subject to over time
- collect information and data to understand the efficiency state of the unit and prevent possible faults

WARNING

Before checking, please verify the following:

- ⇒ *the electrical power supply line should be isolated at the beginning*
- ⇒ *the line isolator device is open, locked and equipped with the suitable warning sign*
- ⇒ *make sure no tension is present*
- ⇒ *After switching the power off, wait at least 5 minutes before accessing to the electrical panel or any other electrical component.*
- ⇒ *Before accessing check with a multimeter that there are no residual stresses.*

Frequency of interventions

Perform an inspection every 6 months.

However, frequency depends on the type of use.

Pan inspections at close intervals in the event of:

- frequent use (continuous or very intermittent use, near the operating limits, etc)
- critical use (service necessary)

Unit booklet

Foresee a unit schedule to keep trace of the interventions made on the unit.

In this way, it will be easier to adequately schedule the various interventions and facilitate any troubleshooting.

On the schedule note:

- date
- intervention description
- carried out measures etc.





Checklist for recommended regular checks

Danger

⇒ **Disconnect the power supply before each operation**

		intervention frequency (months)		
		1	6	12
1	Air filter (inlet/outlet)	X		
2	Inner storage tank		X	
3	Electric heater		X	
4	Safety valve			X
5	Water filter			X
6	Expansion vessel			X
7	Checking for leaks*			X

⇒ **Refer to the local provisions for implementation; in an extremely brief and purely indicative manner, the regulation specifies the following.*

⇒ *Companies and technicians carrying out installation, maintenance/repair interventions, checks for losses and recovery operations must be CERTIFIED in accordance with the local regulations.*

⇒ *The check for losses must be carried out on an annual basis.*

Notes/interventions suggested to the owner

Water temperature

It is recommended to set a lower temperature to decrease the heat release, prevent scale and save energy if the outlet water volume is sufficient.

Standby mode

In some cold areas (under 0°C), if the system will be stopped for a long time, empty the storage tank in order to avoid the water freezing and damage of E-heater.

If a long period of inactivity is foreseen:

- put the unit in OFF
- wait a few minutes to allow all the actuators to reach the rest position
- Turn off the power in order to avoid electrical risks or damages by lightning strikes
- Evacuate all the water storage tank and the pipeline and close all the valves;

Note

⇒ *It's recommended that the starting-up after the stopping period is performed by a qualified technician, especially after seasonal stops or seasonal switch.*

When restarting, refer to what is indicated in the START-UP section.

Schedule technical assistance in advance to avoid hitches and to guarantee that the system can be used when required.



Power supply

Check the connection between power supply plug and socket and ground wiring regularly;

Electronic anode

The unit is equipped with a dynamic system for the tank active protection from corrosion.

The anode is in active titanium.

Periodical substitutions are not foreseen or maintenance.

Filter cleaning

The air filter blocks dust.

If the filter is blocked, the unit will not work as well.

The operating with clogged filters leads to a reduction of the air flow, leading to malfunctions and unit shutdowns.

Approximately, cleaning should ideally take place between weekly and monthly. It is advisable to start with frequent checks, and to adjust the frequency based on how much dirt is discovered.

A	Air outlet
B	Air inlet
C	Air filter

In terms of the filter set in air inlet directly (namely, air inlet without connect with canvas), the method of dismantle the filter is:

- anti-clockwise unscrew the air inlet (1) ring, take out the filter (2) and clean it completely, finally, remount it to the unit.

Condensate discharge

Dust and deposits could cause obstructions .

In addition in the pan can proliferate microorganisms and moulds.

It is very important to provide a periodic cleaning with appropriate detergents and in case a disinfection with sanitizing products.

⇒ *After cleaning pour water into the pan to ensure a regular flow.*

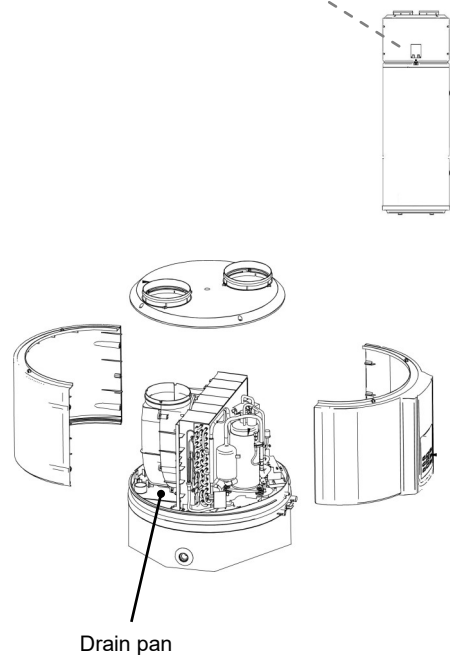
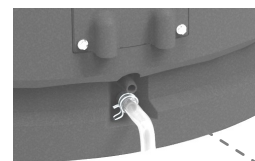
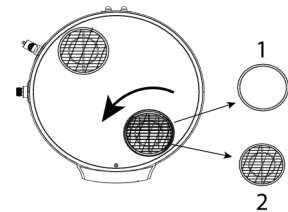
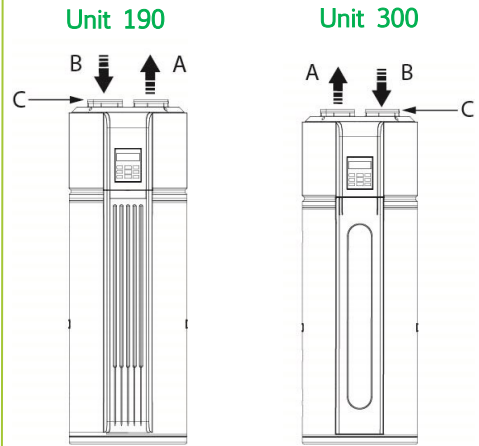



Storage tank

It is recommended to clean the inner storage tank and electric heater to keep an efficient performance.

Storage tank emptying

If the unit needs cleaning, moving etc, the storage tank should be emptied.

Switch off the unit:

- 1 close the cool water inlet valve (1);
- 2 open valve the domestic hot water (DHW) outlet valve (2);
- 3 open drainpipe (3)

Beware of your body for burns.

⇒ The outlet water temperature maybe very high when emptying

Replace or control the electric heater

If the replace or control of the electric heater

⇒ Remove power supply

- Remove frontal cover (A)
- Unscrew the screws and remove the cover cap (B)
- Turn off the water inlet valve (C)
- Open hot water tap for decrease the pressure of the storage tank.
- Open tap (D)
- Empty the storage up to point (E)
- Disconnect the cable from the electric heater
- Remove and replace the electric heater (If faulty)
- Install the electrical resistance and make sure effective sealed.
- Check that there are no water losses from the fitting
- Restore the electric connections
- Put the cover cap (B) and fix
- Put de frontal cover (A)
- Open the water inlet tap (C) until water flows out from outlet tap, then turn of water outlet tap.
- Power on then restart the unit.

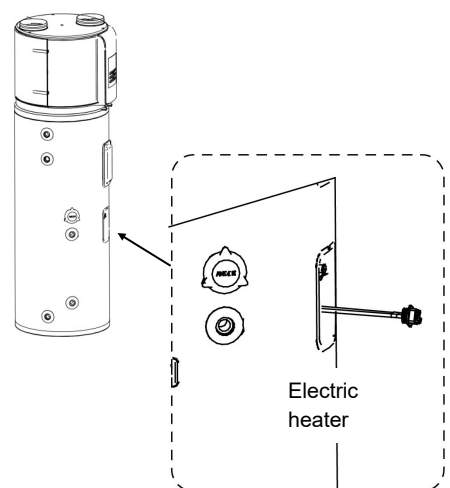
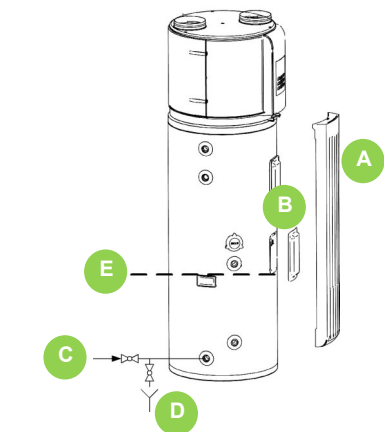
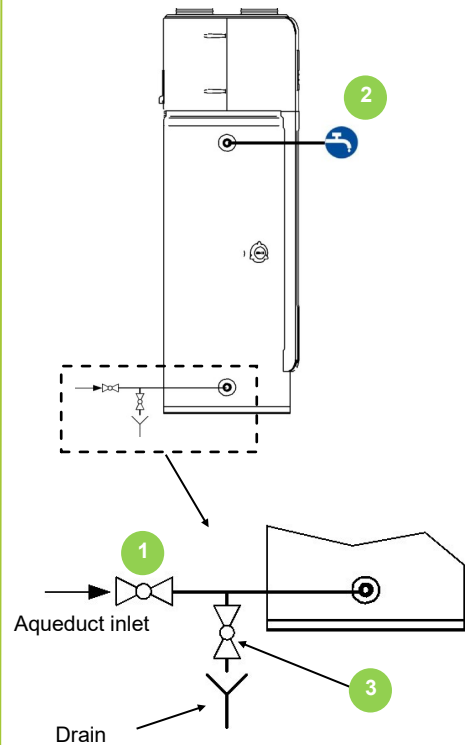



Coil

⇒ *Accidental contact with the exchanger flaps can cause injuries from cut: use protective gloves.*

The coil must allow maximum thermal exchange, therefore, the surface must be clear from dirt and scaling.

Clean the air inlet side.

Use a soft brush or aspirator.

Check the aluminium flaps have not been damaged or folded, otherwise will be from "comb" the coil for excellent air flow. (contact an authorised after-sales assistance centre)

Safety valve

The safety valves must be checked regularly.

Almost all losses are caused by impurities deposited inside the valve.

It's normal if some water drops from the hole of safety valve during operation. But, if there is a great amount of water, call your service agent for instructions

If water doesn't flow freely when operating the handle, replace safety valve with a new one

Nota

⇒ *Please beware of burn, beware of the hot water from the valve.*

To clean the valve:

- Manually open the valve
- Turn the knob as indicated by the arrow on the knob itself

Expansion tank

Check the expansion vessel charge (at least once a year).

First check that the expansion vessel is totally drained of water.

If you necessary load with nitrogen, take care that the pressure does not exceed the value indicated on the label.

Structure

Check the condition of the structure parts .

Paint so as to eliminate or reduce oxidation where needed.

Check that the paneling is correctly fastened. Poor fastening may give rise to malfunctions and abnormal noise and vibration .

Restart after a long term stop

When the unit is restarted after a long term stop (included trial running), it is normal that outlet water is unclean. Keep the tap on and the water will be clean soon.

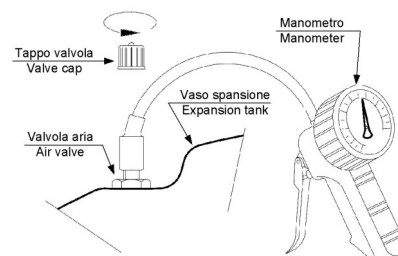

General

In this section the most common situations are signalled. As these cannot be controlled by the manufacturer these could be a source of risk situations for people or things.

Danger zone

This is an area in which only an authorised operator may work. The danger zone is the area inside the unit which is accessible only with the deliberate removal of protections or parts thereof.

Handling

The handling operations, if implemented without all of the protection necessary and without due caution, may cause the fall or the tipping of the unit with the consequent damage, even serious, to persons, things or the unit itself. Handle the unit following the instructions provided in the present manual regarding the packaging and in compliance with the local regulations in force.

Should the gas refrigerant leak please refer to the refrigerant "Safety sheet".

Installation

An incorrect installation of the unit could cause water leaks, condensate accumulation, leaking of the refrigerant, electric shock, bad functioning or damage to the unit itself.

Check that the installation has been implemented by qualified technical personnel only and that the instructions contained in the present manual and the local regulations in force have been adhered to. The installation of the unit in a place where even infrequent leaks of inflammable gas and the accumulation of this gas in the area surrounding the area occur could cause explosions or fires. Carefully check the positioning of the unit. The installation of the unit in a place unsuited to support its weight and/or guarantee adequate anchorage may cause the fall or the tipping of the unit with the consequent damage to things, people or the unit itself. Carefully check the positioning and the anchoring of the unit.

Easy access to the unit by children, unauthorised persons or animals may be the source of accidents, some serious.

Install the unit in areas which are only accessible to authorised person and/or provide protection against intrusion into the danger zone .

General risks

Smell of burning, smoke or other signals of serious anomalies may indicate a situation which could cause damage to people, things or the unit itself. Electrically isolate the unit (yellow-red isolator).

Contact the authorised service centre to identify and resolve the problem at the source of the anomaly.

Accidental contact with exchange batteries, compressors, air delivery pipes or other components may cause injuries and/or burns. Always wear suitable clothing including protective gloves to work inside the danger zone.

Maintenance and repair operations carried out by non-qualified personnel may cause damage to persons, things or the unit itself.

Always contact the qualified assistance centre.

Failing to close the unit panels or failure to check the correct tightening of all of the panelling fixing screws may cause damage to persons, things or the unit itself. Periodically check that all of

the panels are correctly closed and fixed. If there is a fire the temperature of the refrigerant could reach values that increase the pressure to beyond the safety valve with the consequent possible projection of the refrigerant itself or explosion of the circuit parts that remain isolated by the closure of the tap. Do not remain in the proximity of the safety valve .

and never leave the refrigerating system taps closed.

Electric parts

An incomplete attachment line to the electric network or with incorrectly sized cables and/or unsuitable protective devices can cause electric shocks, intoxication, damage to the unit or fires. Carry out all of the work on the electric system referring to the electric layout and the present manual ensuring the use of a system thereto dedicated. An incorrect fixing of the electric components cover may favour the entry of dust, water etc inside and may consequently can electric shocks, damage to the unit or fires.

Always fix the unit cover properly. When the metallic mass of the unit is under voltage and is not correctly connected to the earthing system it may be as source of electric shock and electrocution.

Always pay particular attention to the implementation of the earthing system connections. Contact with parts under voltage accessible inside the unit after the removal of the guards can cause electric shocks, burns and electrocution.

Open and padlock the general isolator prior to removing the guards and signal work in progress with the appropriate shield. Contact with parts that could be under voltage due to the start up of the unit may cause electric shocks, burns and electrocution.

When voltage is necessary for the circuit open the isolator on the attachment line of the unit itself, padlock it and display the appropriate warning shield.

Moving parts

Contact with the transmissions or with the fan aspiration can cause injuries. Prior to entering the inside of the unit open the isolater situated on the connection line of the unit itself, padlock and display the suitable sign.

Contact with the fans can cause injuries.

to removing the protective grill or the fans, open the isolator on the attachment line of the unit itself, padlock it and display the appropriate warning sign.

Refrigerant

The intervention of the safety valve and the consequent expulsion of the gas refrigerant may cause injuries and intoxication. Always wear suitable clothing including protective gloves and eyeglasses for operations inside the danger zone.

Should the gas refrigerant leak please refer to the refrigerant "Safety sheet".

Contact between open flames or heat sources with the refrigerant or the heating of the gas circuit under pressure (e.g. during welding operations) may cause explosions or fires.

Do not place any heat source inside the danger zone.

The maintenance or repair interventions which include welding must be carried out with the system off.

Hydraulic parts

Defects in ducting , the attachments or the cut-off parts may cause a leak or water projection with the consequent damages to people, things or shortcircuit the unit.

Disconnection

Only authorised personnel must disconnect the unit.

Avoid leak or spills into the environment.

Before disconnecting the unit, the following must be recovered, if present:

⇒ *refrigerant gas*

When awaiting dismantling and disposal, the unit can also be stored outdoors, as bad weather and rapid changes in temperature will not cause damage to the environment, if the unit's electric, cooling and hydraulic circuits are integral and closed.

DISPOSAL

CE WEEE DIRECTIVE

The manufacturer is registered on the EEE National Register, in compliance with implementation of Directive 2012/19/EU and relevant national regulations on waste electrical and electronic equipment.

This Directive requires electrical and electronic equipment to be disposed of properly.

Equipment bearing the crossed-out wheelee bin mark must be disposed of separately at the end of its life cycle to prevent damage to human health and to the environment.

Electrical and electronic equipment must be disposed of together with all of its parts.

To dispose of "household" electrical and electronic equipment, the manufacturer recommends you contact an authorised dealer or an authorised ecological area.

"Professional" electrical and electronic equipment must be disposed of by authorised personnel through established waste disposal authorities around the country.

In this regard, here is the definition of household WEEE and professional WEEE:

WEEE from private households: WEEE originating from private households and WEEE which comes from commercial, industrial, institutional and other sources which, because of its nature and quantity, is similar to that from private households. Subject to the nature and quantity, where the waste from EEE was likely to have been by both a private household and users of other than private households, it will be classed as private household WEEE;

Professional WEEE: all WEEE which comes from users other than private households.

This equipment may contain:

⇒ *refrigerant gas, the entire contents of which must be recovered in suitable containers by specialised personnel with the necessary qualifications;*

⇒ *lubrication oil contained in compressors and in the cooling circuit to be collected;*

⇒ *mixtures with antifreeze in the water circuit, the contents of which are to be collected;*

⇒ *mechanical and electrical parts to be separated and disposed of as authorised.*

When machine components to be replaced for maintenance purposes are removed or when the entire unit reaches the end of its life and needs to be removed from the installation, waste should be separated by its nature and disposed of by authorised personnel at existing collection centres.

Dismantling and disposal

THE UNIT MUST ALWAYS BE SENT TO AUTHORISED CENTRES FOR DISMANTLING AND DISPOSAL.

When dismantling the unit, the fan, the motor and the coil, if operating, may be recovered by the specialist centres for reuse. All the materials must be recovered or disposed of in compliance with the corresponding national standards in force.

For further information on the decommissioning of the unit, contact the manufacturer.



Dimensional 190 - 190S

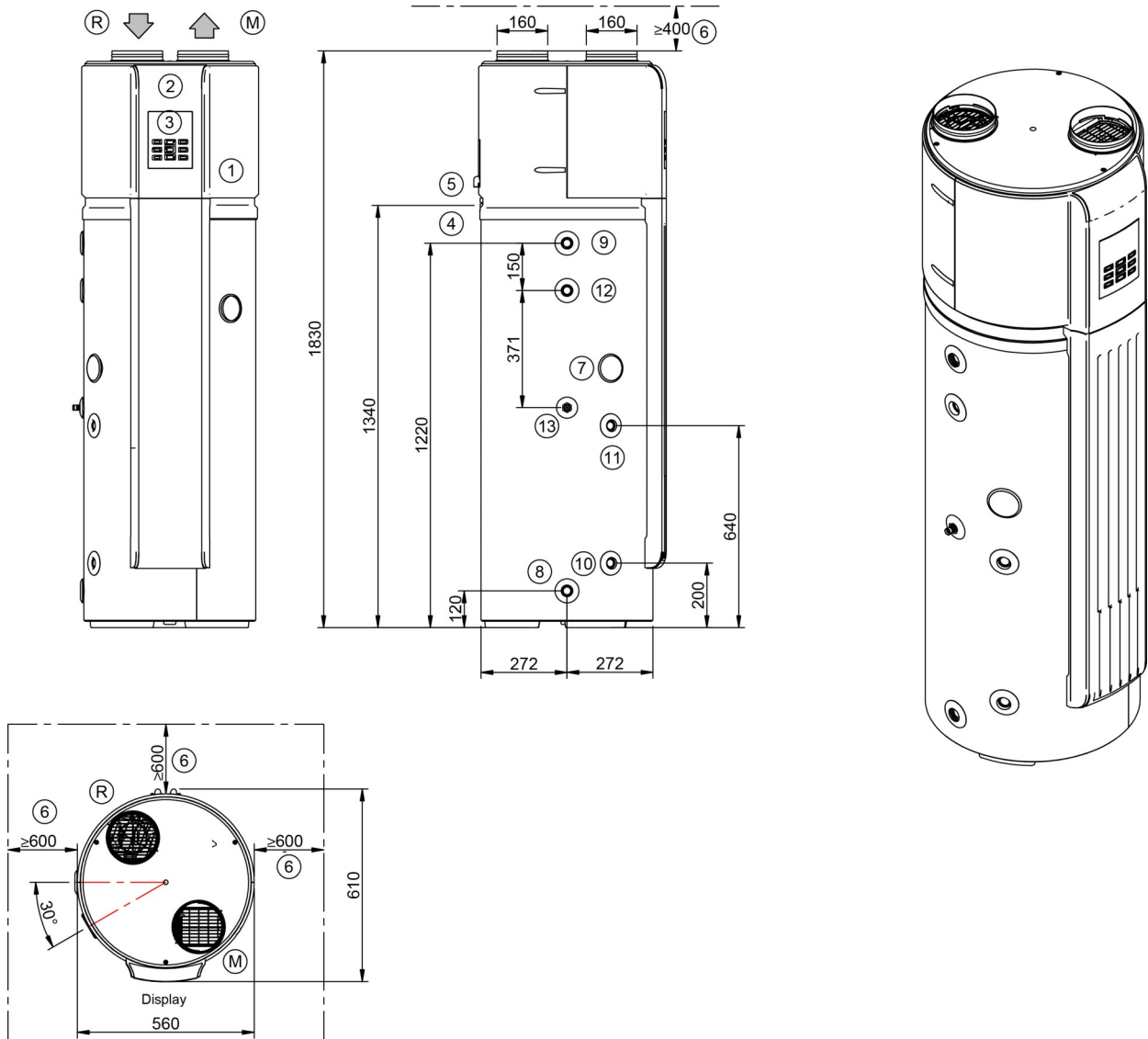

1	Compressor compartment	6	Functional spaces	11	Solar outlet 3/4" F (only 190S)
2	Electric panel	7	Anode	12	Domestic hot water recirculation (only 190S)
3	Unit keypad	8	Water inlet 3/4" F	13	Probe sump for solar
4	Electric line input	9	Water outlet 3/4" F	R	Air inlet
5	Condensate drain	10	Solar inlet 3/4" F (only 190S)	M	Air supply

Size			190	190S
Operating weight	kg		268	277
Shipping weight	kg		114	131
Shipping height	mm		2070	2070
Shipping depth	mm		680	680
Shipping width	mm		680	680

Dimensional
300 - 300S

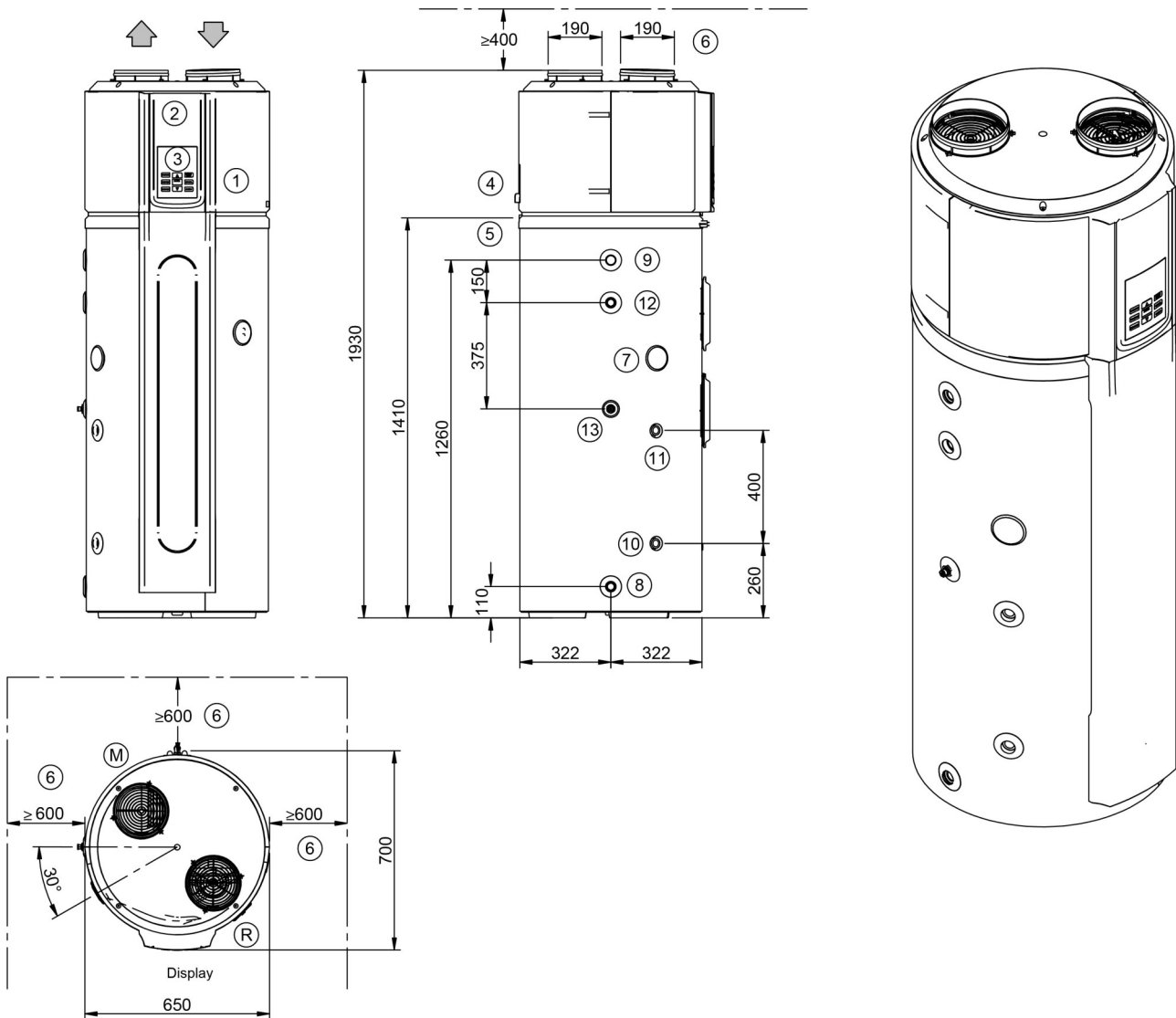

1	Compressor compartment	6	Functional spaces	11	Solar outlet 3/4" F (only 300S)
2	Electric panel	7	Anode	12	Domestic hot water recirculation (only 300S)
3	Unit keypad	8	Water inlet 3/4" F	13	Probe sump for solar
4	Electric line input	9	Water outlet 3/4" F	R	Air inlet
5	Condensate drain	10	Solar inlet 3/4" F (only 300S)	M	Air supply

Size		300	300S
Operating weight	kg	398	406
Shipping weight	kg	138	158
Shipping height	mm	2200	2200
Shipping depth	mm	775	775
Shipping width	mm	745	745

General Technical

Size			190	300	190S	300S
Power and Efficiency						
Tout 15/12°C (DB/WB), Tw,in 15 °C Tw,out 45°C	Thermal power	kW	1,62	2,30	1,62	2,30
	Total power absorbed	kW	0,42	0,53	0,42	0,53
	COP		3,86	4,34	3,86	4,34
Tout 43/26°C (DB/WB), Tw,out 70°C --> 190 Tw,out 65°C --> 300	Thermal power	kW	2,31	3,25	2,31	3,25
	Total power absorbed	kW	0,546	0,627	0,546	0,627
	COP		4,23	5,18	4,23	5,18
Electric heating element		kW	1,50	1,50	1,50	1,50
Standard power supply		V	220-240/1/50			
Heating time DHW	(1)	h/min	3/53	4/22	3/53	4/22
Minimum temperature DHW		°C	7	7	7	7
Maximum temperature DHW	(6)	°C	70	70	70	70
Sound pressure level (1m)	(5)	dB(A)	36,6	38,2	36,6	38,2
Sound power level (L _{WA})		dB(A)	51	53	51	53
ErP						
Clima Average Heat pumps Water Heater (2)	Energy class of generator		A+	A+	A+	A+
	Domestic hot water profile		L	XL	L	XL
	η _{wh}	%	115	123	115	123
	Annual consumption AEC	kWh	890	1356	890	1356
	Daily consumption	kWh	4,22	6,34	4,22	6,34
	COP EN 16147		2,76	3,01	2,76	3,01
Clima Warmer Heat pumps Water Heater (3)	Domestic hot water profile		L	XL	L	XL
	η _{wh}	%	125	143	125	143
	Annual consumption AEC	kWh	819	1173	819	1173
	Daily consumption	kWh	3,86	5,49	3,86	5,49
	COP EN 16147		3,13	3,59	3,13	3,59
Clima Colder Heat pumps Water Heater (4)	Domestic hot water profile		L	XL	L	XL
	η _{wh}	%	99	91	99	91
	Annual consumption AEC	kWh	1034	1845	1034	1845
	Daily consumption	kWh	4,90	8,56	4,90	8,56
	COP EN 16147		2,36	2,32	2,36	2,32
Domestic Hot Water Accumulator						
Volume of Domestic hot water Accumulator	l		176	284	168	272
Maximum operating pressure	bar		10	10	10	10
	MPa		1	1	1	1
Material of accumulator tank		Enamel Steel				
Insulation Material		Polyurethane foam				
Insulation Thickness	mm		50	50	50	50
Refrigerant Circuit						
Compressor type			Rotary	Rotary	Rotary	Rotary
Refrigerant Gas			R134-a	R134-a	R134-a	R134-a
Quantity of refrigerant	kg		1,10	1,40	1,10	1,40
GWP	t		1430	1430	1430	1430
Tonne of CO2 equivalents	t _{CO2}		1,57	2,00	1,57	2,00
Oil quantity	ml		350	350	350	350
Type of expansion valve			Electronic	Electronic	Electronic	Electronic

13 TECHNICAL DATA

Size		190	300	190S	300S
Ventilation					
Type of fan		Centrifugal			
Air flow	m ³ /h	270	414	270	414
Available pressure head	Pa	25	45	25	45
Integration					
Solar coil surface	m ²	-	-	1,10	1,30
Solar coil material		-	-	Enamel Steel	
Maximum operating pressure	bar	-	-	10	10
	MPa	-	-	1	1

1. Inlet water temperature 15 °C, accumulator set 45°C, air on source side 15°C D.B /12°C W.B.
2. The product complies with the European Directive ErP, which includes the Commission Delegated Regulation (EU) N. 812/2013 and the Commission Delegated Regulation N. 814/2013, Average Climate, Heat Pump Water Heater
3. The product complies with the European Directive ErP, which includes the Commission Delegated Regulation (EU) N. 812/2013 and the Commission Delegated Regulation N. 814/2013, Warmer Climate, Heat Pump Water Heater
4. The product complies with the European Directive ErP, which includes the Commission Delegated Regulation (EU) N. 812/2013 and the Commission Delegated Regulation N. 814/2013, Colder Climate, Heat Pump Water Heater
5. Data referred to completely ducted unit.
6. Maximum temperature that can be reached during Anti-legionella mode(Dinsifect)
*It contains fluorinated greenhouse gases

Electrical data

Size		190	300	190S	300S
Power supply	(1) V	220-240/1/50	220-240/1/50	220-240/1/50	220-240/1/50
F.L.A. - Current absorbed at the maximum allowed conditions	A	9,10	9,80	9,10	9,80
F.L.I. - Power absorbed at full load (at the maximum allowed conditions)	kW	2,10	2,25	2,10	2,25
M.I.C - Maximum inrush current	A	22,2	33,7	22,2	33,7

- 1) Power supply 220-240/1/50 Hz
For power voltages other than the standard, contact the Clivet technical department
The units are conforming with the prescriptions of European Standards CEI EN 60204 and CEI EN 60335

Warning: when defining the correct size, verify that all absorption is compliant with current electrical supply contracts in force in the country of installation

Operating limits

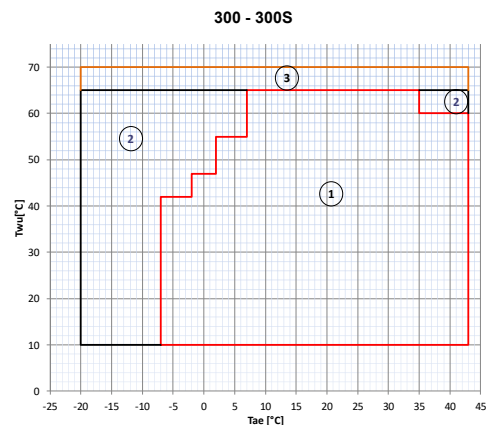
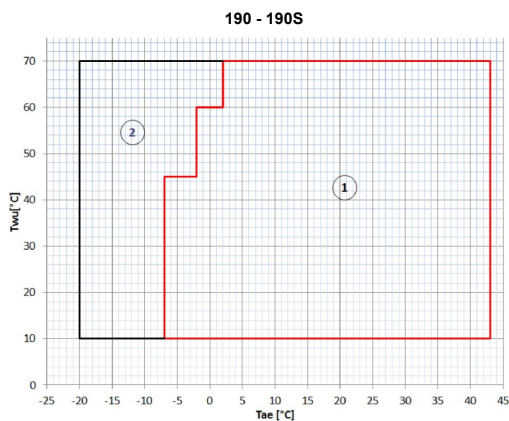

- | | |
|--|--|
| <ol style="list-style-type: none"> 1. Use range of the heat pump 2. Use range of the electrical heating element 3. Use range of the electrical heating element only in Anti-Legionella mode | <p>(Disinfect)
T_{wu} [°C] water temperature in the accumulator
T_{ae} [°C] air temperature at exchanger inlet</p> |
|--|--|

Product fiche: water heaters / Scheda prodotto: scaldacqua			
Supplier's name / Nome del fornitore	1		Clivet S.p.A
Series / Serie	2		SWAN-2
Model / Modello	3		SWAN-2 190
Size / Grandezza	4		190
Declared load profile / Profilo di carico dichiarato	5		L
Class / Classe	6		A+
η_{wh}	7	%	115
Q_{HE}	8	kWh	890
Thermostat temperature settings / Impostazioni di temperatura del termostato	9		53
L_{WA_IN}	10	dB	51
Precautions / Precauzioni	11		see use and maintenance manual
Enabled smart control settings / Impostazioni con controllo intelligente attivato	12		

Legend:

- ¹ Supplier's name or trademark.
- ² Supplier's model identifier.
- ⁵ Declared load profile, expressed by the appropriate letter and typical usage in accordance with Table 3 of Annex VII;
- ⁶ Water heating energy efficiency class of the model, determined in accordance with point 1 of Annex II, whereby: for solar water heaters and heat pump water heaters, under average climate conditions;
- ⁷ Water heating energy efficiency in %, rounded to the nearest integer and calculated in accordance with point 3 of Annex VIII, whereby: for solar water heaters and heat pump water heaters, under average climate conditions;
- ⁸ Annual electricity consumption in kWh in terms of final energy and/or the annual fuel consumption in GJ in terms of GCV, rounded to the nearest integer and calculated in accordance with point 4 of Annex VIII, whereby: for solar water heaters and heat pump water heaters, under average climate conditions;
- ⁹ Thermostat temperature settings of the water heater, as placed on the market by the supplier;
- ¹⁰ The sound power level LWA , indoors, in dB, rounded to the nearest integer (for heat pump water heaters if applicable);
- ¹¹ Any specific precautions that shall be taken when the water heater is assembled, installed or maintained;
- ¹² Where the value of smart is declared as being '1', an indication that the information on water heating energy efficiency, annual electricity and fuel consumption, as applicable, relate to enabled smart control settings only;

Product fiche: water heaters / Scheda prodotto: scaldacqua			
Supplier's name / Nome del fornitore	1		Clivet S.p.A
Series / Serie	2		SWAN-2
Model / Modello	3		SWAN-2 190S
Size / Grandezza	4		190S
Declared load profile / Profilo di carico dichiarato	5		L
Class / Classe	6		A+
η_{wh}	7	%	115
Q_{HE}	8	kWh	890
Thermostat temperature settings / Impostazioni di temperatura del termostato	9		53
L_{WA_IN}	10	dB	51
Precautions / Precauzioni	11		see use and maintenance manual
Enabled smart control settings / Impostazioni con controllo intelligente attivato	12		

Legend:

- ¹ Supplier's name or trademark.
- ² Supplier's model identifier.
- ⁵ Declared load profile, expressed by the appropriate letter and typical usage in accordance with Table 3 of Annex VII;
- ⁶ Water heating energy efficiency class of the model, determined in accordance with point 1 of Annex II, whereby: for solar water heaters and heat pump water heaters, under average climate conditions;
- ⁷ Water heating energy efficiency in %, rounded to the nearest integer and calculated in accordance with point 3 of Annex VIII, whereby: for solar water heaters and heat pump water heaters, under average climate conditions;
- ⁸ Annual electricity consumption in kWh in terms of final energy and/or the annual fuel consumption in GJ in terms of GCV, rounded to the nearest integer and calculated in accordance with point 4 of Annex VIII, whereby: for solar water heaters and heat pump water heaters, under average climate conditions;
- ⁹ Thermostat temperature settings of the water heater, as placed on the market by the supplier;
- ¹⁰ The sound power level LWA , indoors, in dB, rounded to the nearest integer (for heat pump water heaters if applicable);
- ¹¹ Any specific precautions that shall be taken when the water heater is assembled, installed or maintained;
- ¹² Where the value of smart is declared as being '1', an indication that the information on water heating energy efficiency, annual electricity and fuel consumption, as applicable, relate to enabled smart control settings only;

Product fiche: water heaters / Scheda prodotto: scaldacqua			
Supplier's name / Nome del fornitore	1		Clivet S.p.A
Series / Serie	2		SWAN-2
Model / Modello	3		SWAN-2 300
Size / Grandezza	4		300
Declared load profile / Profilo di carico dichiarato	5		XL
Class / Classe	6		A+
η_{wh}	7	%	123
Q_{HE}	8	kWh	1361
Thermostat temperature settings / Impostazioni di temperatura del termostato	9		54
L_{WA_IN}	10	dB	53
Precautions / Precauzioni	11		see use and maintenance manual
Enabled smart control settings / Impostazioni con controllo intelligente attivato	12		

Legend:

- ¹ Supplier's name or trademark.
- ² Supplier's model identifier.
- ⁵ Declared load profile, expressed by the appropriate letter and typical usage in accordance with Table 3 of Annex VII;
- ⁶ Water heating energy efficiency class of the model, determined in accordance with point 1 of Annex II, whereby: for solar water heaters and heat pump water heaters, under average climate conditions;
- ⁷ Water heating energy efficiency in %, rounded to the nearest integer and calculated in accordance with point 3 of Annex VIII, whereby: for solar water heaters and heat pump water heaters, under average climate conditions;
- ⁸ Annual electricity consumption in kWh in terms of final energy and/or the annual fuel consumption in GJ in terms of GCV, rounded to the nearest integer and calculated in accordance with point 4 of Annex VIII, whereby: for solar water heaters and heat pump water heaters, under average climate conditions;
- ⁹ Thermostat temperature settings of the water heater, as placed on the market by the supplier;
- ¹⁰ The sound power level LWA, indoors, in dB, rounded to the nearest integer (for heat pump water heaters if applicable);
- ¹¹ Any specific precautions that shall be taken when the water heater is assembled, installed or maintained;
- ¹² Where the value of smart is declared as being '1', an indication that the information on water heating energy efficiency, annual electricity and fuel consumption, as applicable, relate to enabled smart control settings only;

Product fiche: water heaters / Scheda prodotto: scaldacqua			
Supplier's name / Nome del fornitore	1		Clivet S.p.A
Series / Serie	2		SWAN-2
Model / Modello	3		SWAN-2 300S
Size / Grandezza	4		300S
Declared load profile / Profilo di carico dichiarato	5		XL
Class / Classe	6		A+
η_{wh}	7	%	123
Q_{HE}	8	kWh	1361
Thermostat temperature settings / Impostazioni di temperatura del termostato	9		54
L_{WA_IN}	10	dB	53
Precautions / Precauzioni	11		see use and maintenance manual
Enabled smart control settings / Impostazioni con controllo intelligente attivato	12		

Legend:

- ¹ Supplier's name or trademark.
- ² Supplier's model identifier.
- ⁵ Declared load profile, expressed by the appropriate letter and typical usage in accordance with Table 3 of Annex VII;
- ⁶ Water heating energy efficiency class of the model, determined in accordance with point 1 of Annex II, whereby: for solar water heaters and heat pump water heaters, under average climate conditions;
- ⁷ Water heating energy efficiency in %, rounded to the nearest integer and calculated in accordance with point 3 of Annex VIII, whereby: for solar water heaters and heat pump water heaters, under average climate conditions;
- ⁸ Annual electricity consumption in kWh in terms of final energy and/or the annual fuel consumption in GJ in terms of GCV, rounded to the nearest integer and calculated in accordance with point 4 of Annex VIII, whereby: for solar water heaters and heat pump water heaters, under average climate conditions;
- ⁹ Thermostat temperature settings of the water heater, as placed on the market by the supplier;
- ¹⁰ The sound power level LWA , indoors, in dB, rounded to the nearest integer (for heat pump water heaters if applicable);
- ¹¹ Any specific precautions that shall be taken when the water heater is assembled, installed or maintained;
- ¹² Where the value of smart is declared as being '1', an indication that the information on water heating energy efficiency, annual electricity and fuel consumption, as applicable, relate to enabled smart control settings only;



CLIVET DECLARATION OF CONFORMITY EU

DICHIARAZIONE DI CONFORMITÀ UE
KONFORMITÄTSEKTLÄRUNG EU
DECLARATION DE CONFORMITE EU
DECLARACIÓN DE CONFORMIDAD EU

WE DECLARE UNDER OUR SOLE RESPONSIBILITY THAT THE MACHINE

DICHIARIAMO SOTTO LA NOSTRA SOLA RESPONSABILITÀ CHE LA MACCHINA
WIR ERKLÄREN EIGENVERANTWORTLICH, DASS DIE MASCHINE
NOUS DÉCLARONS SOUS NOTRE SEULE RESPONSABILITÉ QUE LA MACHINE
EL FABRICANTE DECLARA BAJO SU EXCLUSIVA RESPONSABILIDAD QUE LA MÁQUINA

CATEGORY	HEAT PUMP – domestic hot water production
CATEGORIA	POMPA DI CALORE – produzione acqua calda sanitaria
KATEGORIE	WÄRMEPUMPE - warmwasserproduktion
CATEGORIE	POMPE À CHALEUR – production eau chaude sanitaire
CATEGORIA	BOMBA DE CALOR – producción de agua calientesanitaria

TYPE / TIPO / TYP / TYPE / TIPO	SWAN-2 190 – 300
	SWAN-2 190S – 300S

- **COMPLIES WITH THE FOLLOWING EC DIRECTIVES, INCLUDING THE MOST RECENT AMENDMENTS, AND THE RELEVANT NATIONAL HARMONISATION LEGISLATION CURRENTLY IN FORCE:**
- RISULTA IN CONFORMITÀ CON QUANTO PREVISTO DALLE SEGUENTI DIRETTIVE CE, COMPRESSE LE ULTIME MODIFICHE, E CON LA RELATIVA LEGISLAZIONE NAZIONALE DI RECEPIMENTO:
- DEN IN DEN FOLGENDEN EG-RICHTLINIEN VORGESEHENEN VORSCHRIFTEN, EINSCHLIEßLICH DER LETZTEN ÄNDERUNGEN, SOWIE DEN ANGEWANDTEN LANDESGESETZEN ENTSPRICHT:
- EST CONFORME AUX DIRECTIVES CE SUIVANTES, Y COMPRIS LES DERNIÈRES MODIFICATIONS, ET À LA LÉGISLATION NATIONALE D'ACCUEIL CORRESPONDANTE:
- ES CONFORME A LAS SIGUIENTES DIRECTIVAS CE, INCLUIDAS LAS ÚLTIMAS MODIFICACIONES, Y A LA RELATIVA LEGISLACIÓN NACIONAL DE RECEPCIÓN:

<input checked="" type="checkbox"/>	2014/35/UE	Low voltage directive / direttiva bassa tensione Bestimmungen der Niederspannungsrichtlinie / directive basse tension directiva de baja tensión	
<input checked="" type="checkbox"/>	2014/30/UE	Electromagnetic compatibility / compatibilità elettromagnetica Elektromagnetische Verträglichkeit / compatibilité électromagnétique compatibilidad electromagnética	
<input checked="" type="checkbox"/>	2014/53/EU	Radio Equipment Directive / Direttiva sulle apparecchiature radio Richtlinie über Funkanlagen / Directive sur les équipements radio Directiva sobre equipos radioeléctricos	
<input checked="" type="checkbox"/>	2009/125/UE	Ecodesign / Progettazione ecocompatibile / Ecodesign / Éco-conception / Ecodiseño	
<input checked="" type="checkbox"/>	2011/65/UE	2015/863/UE	RoHs
-Unit manufactured and tested according to the followings Standards: -Unità costruita e collaudata in conformità alle seguenti Normative: -Unité construite et testée en conformité avec les Réglementations suivantes -Unidad construida y probada de acuerdo con las siguientes Normativas -Gebautes und geprüftes Gerät nach folgenden Normen			
EN 55014-1 :2017+A11 :2020 EN 55014-2 :2015 EN IEC 61000-3-2:2019 EN 61000-3-3 :2013+A1 :2019 ETSI EN 301 489-1 V 2.2.3 (2019-11) ETSI EN 301 489-17 V3.2.4 (2020-09) ETSI EN 300 328V 2.2.2 (2019-07) EN IEC 62311 :2020 EN 60335-2-40 :2003+A11 :2004+A12 :2005+A1 :2006+A2 :2009+A13 :2012 EN 60335-2-21 :2003+A1 :2005+A2 :2008 EN 62233 :2008 EN 60335-1 :2012+A11 :2014+A13 :2017+A1 :2019+A14 :2019+A2 :2019 EN 62321-1 :2013 EN 62321-2 :2014 EN 62321-3-1 :2014 EN 62321-4 :2014 EN 62321-5 :2014 EN 62321-6 :2015 EN 62321-7-1 :2015 EN 62321-7-2 :2017 EN 62321-8 :2017			

-Responsible to constitute the technical file is the company n° 00708410253 and registered at the Chamber of Commerce of Belluno Italy
-Responsabile a costituire il fascicolo tecnico è la società n° 00708410253 registrata presso la Camera di Commercio di Belluno Italia
-Verantwortliche für die technischen Unterlagen zusammenstellen n° 00708410253 ist das Unternehmen bei der Handelskammer von Belluno Italien registriert
-Responsable pour compiler le dossier technique est la société n°00708410253 enregistrée à la Chambre de Commerce de Belluno en Italie
-Encargado de elaborar el expediente técnico es la empresa n° 00708410253 registrada en la Cámara de Comercio de Belluno Italia

NAME / NOME / VORNAME / PRÉNOM / NOMBRE
 SURNAME / COGNOME / ZUNAME / NOM / APELLIDOS
 FELTRE, 09/08/2021 COMPANY POSITION / POSIZIONE / BETRIEBSPOSITION / FONCTION / CARGO AMMINISTRATORE DELEGATO

STEFANO
 BELLO



CLIVET S.P.A. - Via Camp Lonc, 25 - Z.I. VILLAPAIERA - 32030 FELTRE (BL) - ITALIA
 Cap.Soc. Eur 20.000.000 i.v. C.F. e Reg.Impr. BL n° 00708410253 - R.E.A. n° 66577 - P.I./VAT:IT 00708410253
 Tel. +39 0439 3131 - Fax +39 0439 313300 -Web: www.clivet.it Mail: info@clivet.it PEC: amministrazione.clivet@pec.it - Registro A.E.E. IT0802000001697



Installation by a qualified technician in possession of the technical-professional requisites according to the current national and local regulations in force in the territory.

Scheme 1: the heat pump can also operate when the solar pump is in operation

Electrical connections

CN32	Solar controller signal input	220-240 ~
CN6	Solar pump control	220-240 ~

Operating logic

T5U (Storage tank temp. sensor Upper)	CN32 (in)	CN6 (out)	SOLAR PUMP	Unit
$\leq 60^{\circ}\text{C}$	220-240 ~	220-240 ~	ON	Enabled
$\geq 65^{\circ}\text{C}$	0 ~	0 ~	OFF	Enabled

Note: solar pump must be controlled through AC contactor.
The CN6 is not allowed to drive the pump directly.

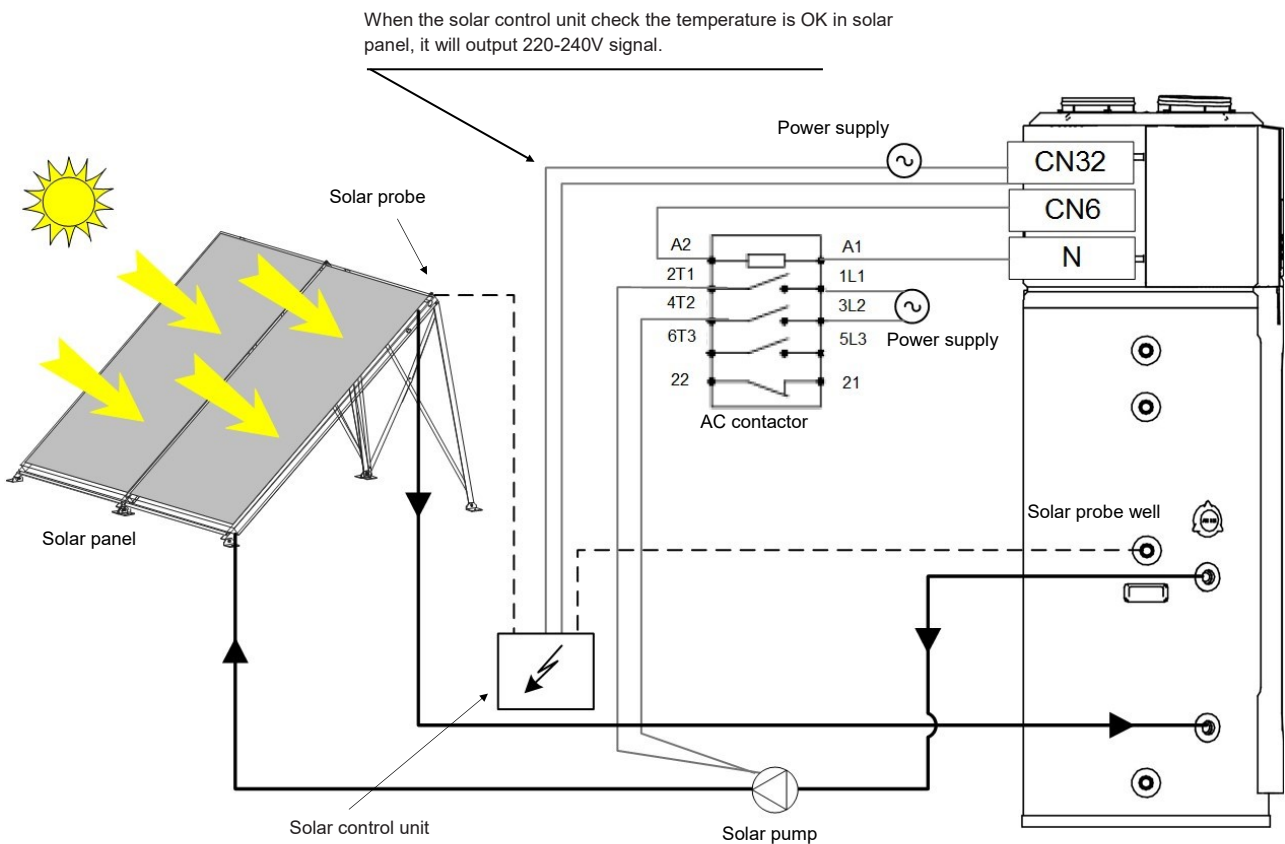

SOLAR SYSTEM (PROVIDED BY THE CUSTOMER)



Scheme 2: the heat pump cannot operate together with the solar pump.

Electrical connections

CN32	Solar controller signal input	220-240 ~
CN6	Solar pump control	220-240 ~
CN29	Unit control	Enabled / disabled

Operating logic

T5U (Storage tank temp. sensor Upper)	CN32 (in)	CN6 (out)	SOLAR PUMP	CN29	Unit
$\leq 60^{\circ}\text{C}$	220-240 ~	220-240 ~	ON	ON	Disabled
$\geq 65^{\circ}\text{C}$	0 ~	0 ~	OFF	OFF	Enabled

Note: solar pump must be controlled through AC contactor.

The CN6 is not allowed to drive the pump directly.

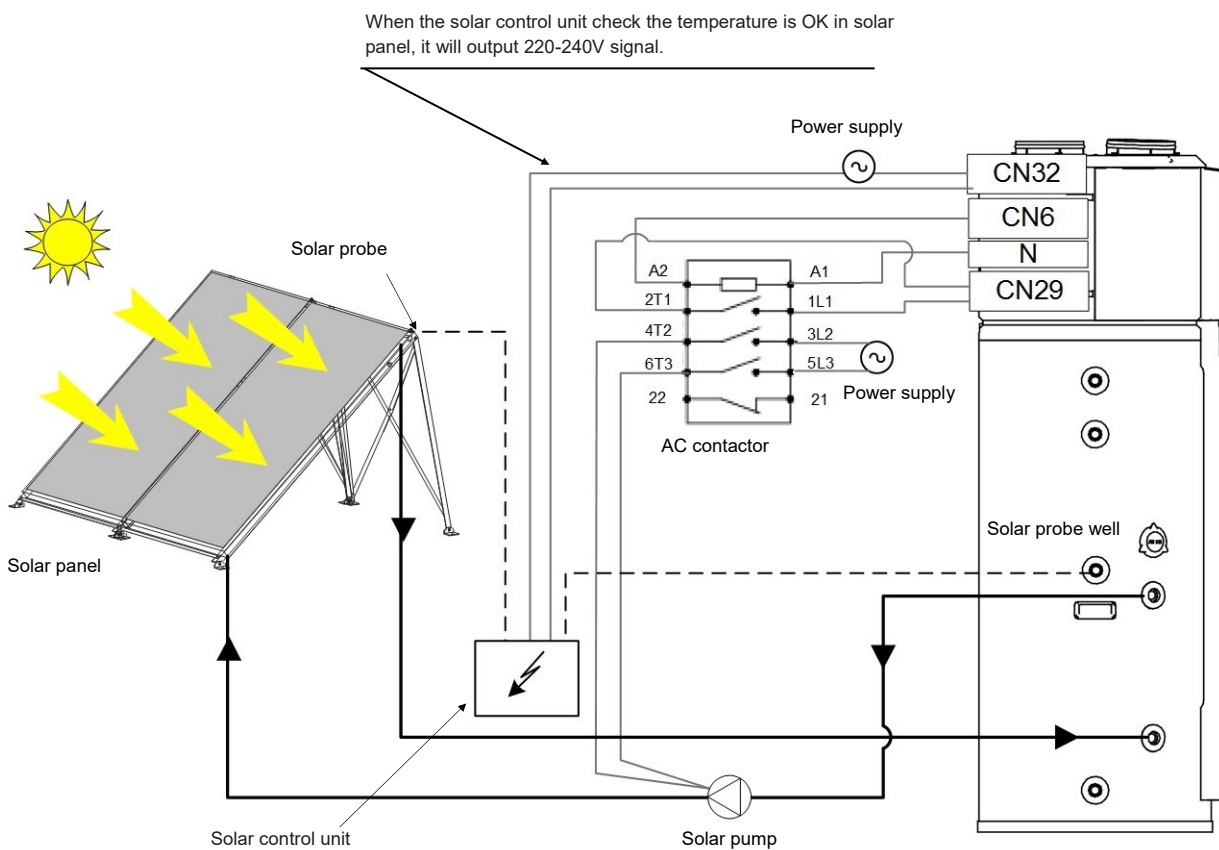



Option

Equipped with:

12Vdc AL12X power supply unit

Ethernet/485 converter

Cat. 5 UTP Ethernet cable (5m long)

For details, see instructions ELFOControl³ EVO manual

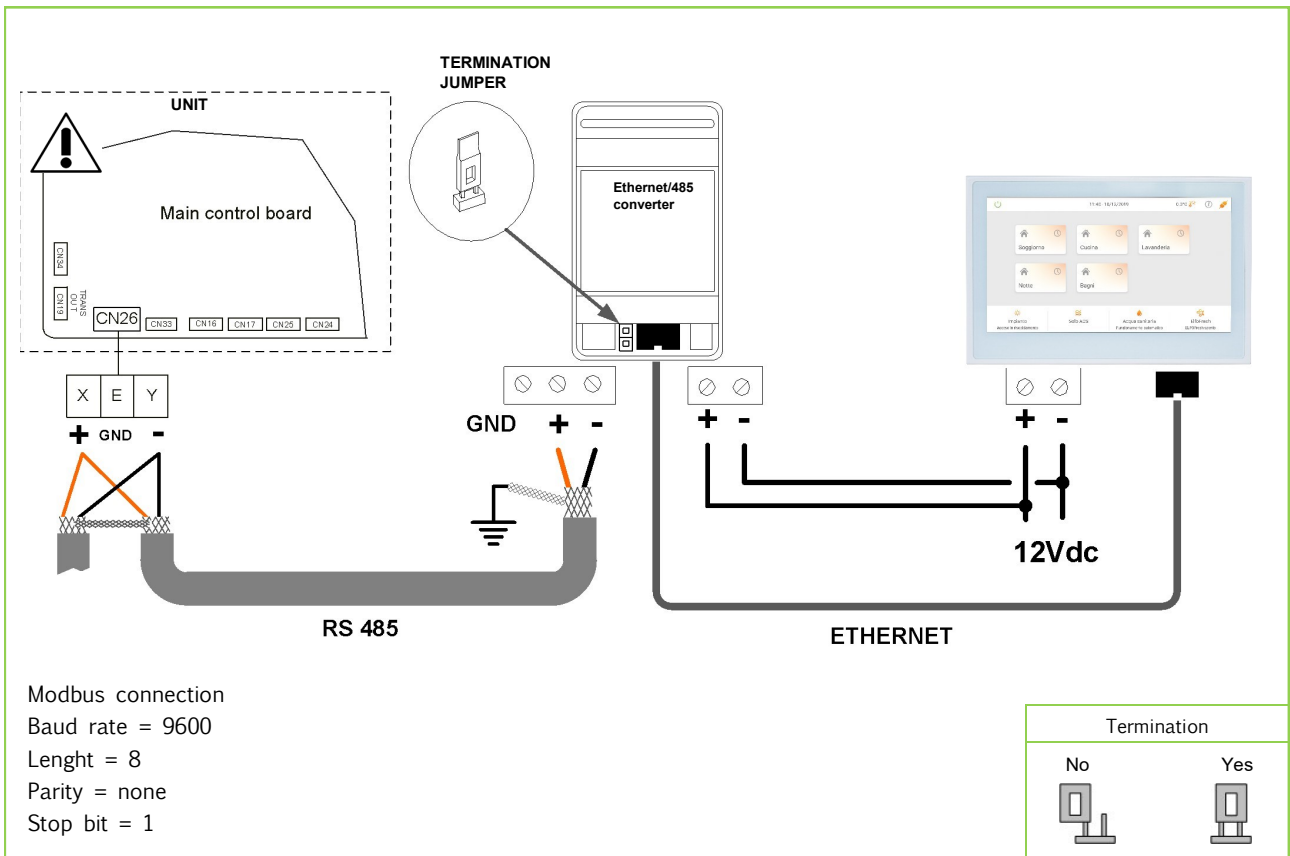

Addressing	
Press 3 sec.	MODE + ▲ + ENTER Press 3 seconds for lock/unlock
Select C02	▲
Press	ENTER Press 3 seconds for lock/unlock
Select 1	▲
Press	ENTER Press 3 seconds for lock/unlock



15 MODBUS PROTOCOL



Unit set read command

Register address	Data content	Remarks	
0	Power on/off	BIT15	Reserved
		BIT14	Reserved
		BIT13	Reserved
		BIT12	Reserved
		BIT11	Reserved
		BIT10	Reserved
		BIT9	Reserved
		BIT8	Reserved
		BIT7	Reserved
		BIT6	Reserved
		BIT5	Reserved
		BIT4	Reserved
		BIT3	Reserved
		BIT2	Reserved
		BIT1	Reserved
		BIT0	0: power off; 1: power on.
1	Setting mode	1:invalid ; 2:hybird 3: e-heater 4:vacation	
2	Setting the temperature Ts	unit: °C. Setting range 38-70°C (actual value) Send value = actual value*2+30 unit: °F. Setting range 100-158°F Send value = actual value	
3	Comand Functions	BIT15	Reserved
		BIT14	Reserved
		BIT13	Reserved
		BIT12	Reserved
		BIT11	Reserved
		BIT10	Reserved
		BIT9	Reserved
		BIT8	Reserved
		BIT7	Reserved
		BIT6	Fahrenheit or Celsius Enable 0 = Celsius Enable 1 = Fahrenheit Enable
		BIT5	Force disinfect function(0 = OFF 1 = ON)
BIT4	Remoter ONOFF (0 = OFF 1 = ON)		
BIT3	Remoter OnOff signal (0 = OFF 1 = ON) 0 = panel's onoff signal check can work 1 = panel's onoff signal check can't work		
BIT2	SG Command (same of digital input)		
BIT1	EVU command (same of digital input)		
BIT0	Solar signal (control Bit 1 and 2) 0 = solar panel can work 1 = solar panel can't work		
4	hour		Decimal
5	minute		Decimal



Register address	Data content	Remarks	
100	Operating mode	1:(invalid) 2:hybird, 3: e-heater, 4:vacation	
101	T5U temperature	Water temperature in upper position of water tank, unit: °C. Send value = actual value*2+30 unit: °F. Send value = actual value	°C
102	T5L temperature	Water temperature in lower position of water tank, unit: °C. Send value = actual value*2+30 unit: °F. Send value = actual value	°C
103	T3 temperature	Condenser temperature unit:°C. Send value = actual value*2+30 unit: °F. Send value = actual value	°C
104	T4 temperature	Outdoor ambient temperature, : °C. Send value = actual value*2+30 unit: °F. Send value = actual value	°C
105	Tp Exhaust gas temperature	Compressor exhaust temperature Tp, unit°C. Send value = actual value unit: °F. Send value = actual value	°C
106	Th temperature	Suction Temp Th, unit: °C. Send value = actual value*2+30 unit: °F. Send value = actual value	°C
107	PMV opening value	External electronic expansion opening valve, unit: P. Send value = actual value	step
108	Compressor current	Input AC current Send value = actual value	A
109	Load output	BIT15	Reserved
		BIT14	Reserved
		BIT13	Reserved
		BIT12	Reserved
		BIT11	Reserved
		BIT10	Reserved
		BIT9	Reserved
		BIT8	Reserved
		BIT7	Alarm On (0 = OFF 1 = ON)
		BIT6	Solar panel water pump On (0 = OFF 1 = ON)
		BIT5	Fan speed: High (0 = OFF 1 = ON)
		BIT4	Fan speed: Medium (0 = OFF 1 = ON)
		BIT3	Fan speed: Low (0 = OFF 1 = ON)
		BIT2	4 way valve (0 = OFF 1 = ON)
BIT1	Electric heater (0 = OFF 1 = ON)		
BIT0	Compressor (0 = OFF 1 = ON)		

15 MODBUS PROTOCOL



Register address	Data content	Remarks	
110	Error Protect Code	1~19 E0~E9,EA,Eb,EC,Ed,EE,EF,EH,EL,EP	
		20~38 P0~P9,PA,Pb,PC,Pd,PE,PF,PH,PL,PP	
		39~57 H0~H9,HA,Hb,HC,Hd,HE,HF,HH,HL,HP	
		58~76 C0~C9,CA,Cb,CC,Cd,CE,CF,CH,CL,CP	
		77~95 L0~L9,LA,Lb,LC,Ld,LE,LF,LH,LL,LP	
		96~114 b0~b9,bA,bb,bC,bd,bE,bF,bH,bL,bP	
111	Maximum of Ts	unit: °C./ °F Send value = actual value	
112	Minimum of Ts	unit: °C. / °F Send value = actual value	
113	Display temperature Tx	unit: °C. Send value = actual value*2+30	
		unit: °F. Send value = actual value	
114	Remaining hot water	Segment:0~4 (Reserved)	
115	Auxiliary Status bit: 1	BIT15	
		BIT14	
		BIT13	
		BIT12	
		BIT11	
		BIT10	
		BIT9	
		BIT8	
		BIT7	
		BIT6	
		BIT5	
		BIT4	
		BIT3	Wifi Connection Status (1 Connect 0 No Connect)
		BIT2	Defrost (1 = active)
		BIT1	Solar kit on/off
BIT0	Vacation mode (1 = active)		
116	Compressor running time	Compressor running time, unit: sec, send value = actual value	
117	Model	1-2 means the size of unit (1=190,2=300)	
118	Main PCB firmware version	1~99 Indicates machine version, which refers to the serial number of the hydrau-	
119	Wire controller firmware ver-	1~99 indicates the wire controller version serial number.	



Unit operation status inquiry

Register address	Data content	Remarks		
100	Operating mode	1:(reserved) 2:hybird 3: e-heater 4:vacation		
101	T5U temperature	Water temperature in upper position of water tank, unit: °C. Send value = actual value*2+30 unit: °F. Send value = actual value	°C	
102	T5L temperature	Water temperature in lower position of water tank, unit: °C. Send value = actual value*2+30 unit: °F. Send value = actual value	°C	
103	T3 temperature	Condenser temperature unit°C. Send value = actual value*2+30 unit: °F. Send value = actual value	°C	
104	T4 temperature	Outdoor ambient temperature, : °C. Send value = actual value*2+30 unit: °F. Send value = actual value	°C	
105	Tp Exhaust gas temperature	Compressor exhaust temperature Tp, unit°C. Send value = actual value unit: °F. Send value = actual value	°C	
106	Th temperature	Suction Temp Th, unit: °C. Send value = actual value*2+30 unit: °F. Send value = actual value	°C	
107	PMV opening value	External electronic expansion opening valve, unit: P. Send value = actual value	step	
108	Compressor current	Input AC current Send value = actual value	A	
109	Load output	BIT15	Reserved	
		BIT14	Reserved	
		BIT13	Reserved	
		BIT12	Reserved	
		BIT11	Reserved	
		BIT10	Reserved	
		BIT9	Reserved	
		BIT8	Reserved	
		BIT7	Alarm On (0 = OFF 1 = ON)	
		BIT6	Solar panel water pump On (0 = OFF 1 = ON)	
		BIT5	Fan speed: High (0 = OFF 1 = ON)	
		BIT4	Fan speed: Medium (0 = OFF 1 = ON)	
		BIT3	Fan speed: Low (0 = OFF 1 = ON)	
		BIT2	4 way valve (0 = OFF 1 = ON)	
BIT1	Electric heater (0 = OFF 1 = ON)			
BIT0	Compressor (0 = OFF 1 = ON)			

15 MODBUS PROTOCOL



Register address	Data content	Remarks	
110	Error Protect Code	1~19 E0~E9,EA,Eb,EC,Ed,EE,EF,EH,EL,EP	
		20~38 P0~P9,PA,Pb,PC,Pd,PE,PF,PH,PL,PP	
		39~57 H0~H9,HA,Hb,HC,Hd,HE,HF,HH,HL,HP	
		58~76 C0~C9,CA,Cb,CC,Cd,CE,CF,CH,CL,CP	
		77~95 L0~L9,LA,Lb,LC,Ld,LE,LF,LH,LL,LP	
		96~114 b0~b9,bA,bb,bC,bd,bE,bF,bH,bL,bP	
111	Maximum of Ts	unit: °C./ °F Send value = actual value	
112	Minimum of Ts	unit: °C. / °F Send value = actual value	
113	Display temperature Tx	unit: °C. Send value = actual value*2+30	
		unit: °F. Send value = actual value	
114	Remaining hot water	Segment:0~4 (Reserved)	
115	Auxiliary Status bit: 1	BIT15	
		BIT14	
		BIT13	
		BIT12	
		BIT11	
		BIT10	
		BIT9	
		BIT8	
		BIT7	
		BIT6	
		BIT5	
		BIT4	
		BIT3	Wifi Connection Status (1 Connect 0 No Connect)
		BIT2	Defrost (1 = active)
		BIT1	Solar kit on/off
BIT0	Vacation mode (1 = active)		
116	Compressor running time	Compressor running time, unit: sec, send value = actual value	
117	Model	1-2 means the size of unit (1=190,2=300)	
118	Main PCB firmware version	1~99 Indicates machine version, which refers to the serial number of the hydrau-	
119	Wire controller firmware ver-	1~99 indicates the wire controller version serial number.	

FOR OVER 30 YEARS, WE HAVE BEEN OFFERING SOLUTIONS TO ENSURE SUSTAINABLE COMFORT AND THE WELL-BEING OF PEOPLE AND THE ENVIRONMENT



sales and assistance

www.clivet.com

MideaGroup
humanizing technology



CLIVET S.p.A.

Via Camp Lonc 25, Z.I. Villapaiera
32032 Feltre (BL) - Italy
Tel. +39 0439 3131 - info@clivet.it

CLIVET GMBH

Hummelsbütteler Steindamm 84,
22851 Norderstedt, Germany
Tel. +49 40 325957-0 - info.de@clivet.com

Clivet Group UK LTD

Units F5 & F6 Railway Triangle,
Portsmouth, Hampshire PO6 1TG
Tel. +44 02392 381235 -
Enquiries@Clivetgroup.co.uk

CLIVET LLC

Office 508-511, Elektrozavodskaya st. 24,
Moscow, Russian Federation, 107023
Tel. +7495 6462009 - info.ru@clivet.com

CLIVET MIDEAST FZCO

Dubai Silicon Oasis (DSO) Headquarter Building,
Office EG-05, P.O Box-342009, Dubai, UAE
Tel. +9714 3208499 - info@clivet.ae

Clivet South East Europe

Jaruščica 9b
10000, Zagreb, Croatia
Tel. +385916065691 - info.see@clivet.com

Clivet Airconditioning Systems Pvt Ltd

Office No.501 & 502,5th Floor, Commercial -I,
Kohinoor City, Old Premier Compound, Off LBS
Marg, Kiroi Road, Kurla West, Mumbai
Maharashtra 400070, India
Tel. +91 22 30930200 - sales.india@clivet.com